

SM-FT-1000 Banding Tool

Operation, Parts & Safety Manual
Original Instructions





Index

Tooling

Depending on set up, this tool is designed to assemble the following HCL Smart® products:

- Smart® Tie 20mm ($\frac{3}{4}$ ")
- Smart® Tie 32mm ($1\frac{1}{4}$ ")
- Smart® Band 19mm ($\frac{3}{4}$ ") Hybrid & Compact
- Smart® Band 32mm ($1\frac{1}{4}$ ") Hybrid & Compact

Follow the instructions described to achieve safe operation.

Note: This tool is not suitable for Smart® Band Standard Systems

Health & Safety

- 1.1 Warning & Safety Instructions

Torque Wrenches

- 2.1 Options

Operation

- 3.1 Using the Tool
- 3.2 Smart® Band Hybrid & Compact

Servicing

- 4.1 Servicing
- 4.2 Troubleshooting
- 4.3 Parts List



Read these instructions carefully:

Whilst Smart® Band and Smart® Tie are considered to be significantly safer than alternative metallic solutions, failure to follow these instructions can still result in personal injury.



General safety considerations:

1. STRAP BREAKAGE HAZARD

Smart® Band and Smart® Tie are free from sharp metallic edges however it is important to understand that improper operation of the tool or sharp corners on the load can result in strap breakage during tensioning that could result in the following:

- A sudden loss of balance causing you to fall
- Both tool and strap flying violently towards your face

Failure to place the strap properly around the load, an unstable or shifted load, could result in a sudden loss of strap tension during tensioning. This could result in a sudden loss of balance causing you to fall.

Positioning yourself in-line with the strap during tensioning, can result in personal injury from flying strap or tool. When tensioning, position yourself to one side of the strap and keep all bystanders away.

2. TRAINING

This tool must not be used by persons not properly trained in its use. Be certain that you receive proper training from your employer. If you have any questions contact your HCL representative.



3. EYE INJURY HAZARD

Failure to wear safety glasses with side shields can result in eye injury or blindness. Always wear safety glasses with side shields which conform to ANSI Standard Z87.1 or EN 166.



4. CUT HAZARD

Although the Smart® Band and Smart® Tie are not metallic and therefore significantly less likely to cause cuts to hands or fingers, it is still strongly recommended that the operator wear protective gloves.

5. FALL HAZARD

Maintaining improper footing and/or balance when operating the tool can cause you to fall. Do not use the tool when you are in an awkward position.

6. TOOL CARE (for further information see Servicing section)

- Inspect and clean the tool daily. Replace all worn or broken parts.
- Lubricate all moving parts approximately every 50 hours of use.
- If used in sea water, wash off immediately with fresh water after use. Dry and lubricate.



Torque Wrenches – Options

Mountz – FGC-10A (Factory set to specified torque – Suitable for Marine use).

For use with:	Material
Smart® Tie 20mm (¾")	PA66 (Nylon 6.6)
	PA12 (Nylon 12)
	PK
	PPS
Smart® Tie 32mm (1¼")	PA12 (Nylon 12)
	PPS
Smart® Band Hybrid 19mm (¾") Smart® Band Compact 19mm (¾")	PA66 (Nylon 6.6)
	PA12 (Nylon 12)
	PPS
	POM (Acetal)



Mountz – FGC-30A (Factory set to specified torque – Suitable for Marine use).

For use with:	Material
Smart® Tie 32mm (1¼")	PK
Smart® Band Hybrid 32mm (1¼") Smart® Band Compact 32mm (1¼")	PA66 (Nylon 6.6)
	PA12 (Nylon 12)
	PPS



Norbar – TTi20 (Variable torque setting – Not advised for Marine use).

For use with:	Material
All product types	PA66 (Nylon 6.6)
	PA12 (Nylon 12)
	PK
	PPS
	POM (Acetal)



2.1

Operation – Using the Tool with Mountz Torque Wrench

NOTE – Steps 1 & 2 are not applicable to Smart® Tie

1

Insert band fully into fixed end of the buckle



2

Pull back band to engage latch teeth and push down firmly on the latch using the thumb or finger to ensure full engagement



WARNING – Ensure latch is fully engaged with band before tightening. Latch not fully engaged could lead to premature failure of system when tightening

3

Wrap band around the application...
...and insert band into other end of buckle

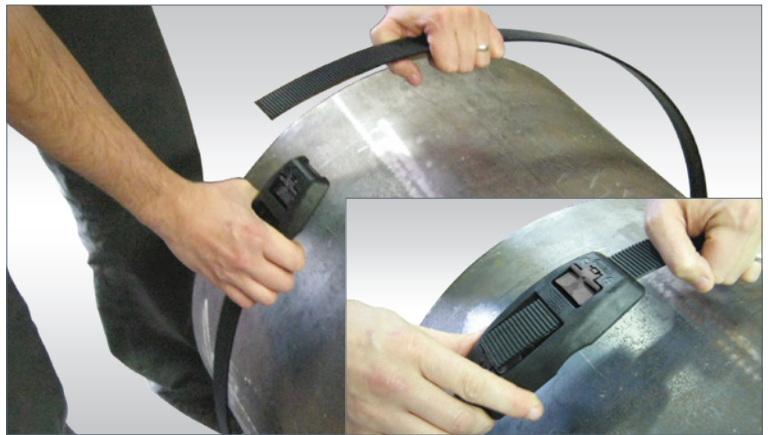

4

Pull band tight by hand, making sure teeth are fully engaged with band

5

Attach Torque wrench to the square drive at the rear of the tool.

Optional – Lock Torque wrench to square drive using a 4mm hexagon key



3.1

Operation - Using the Tool with Mountz Torque Wrench

IMPORTANT – If Mountz type torque wrench is being utilised follow steps 6-9 followed by 18-20

6

Is yellow marker in the '0mm' position?

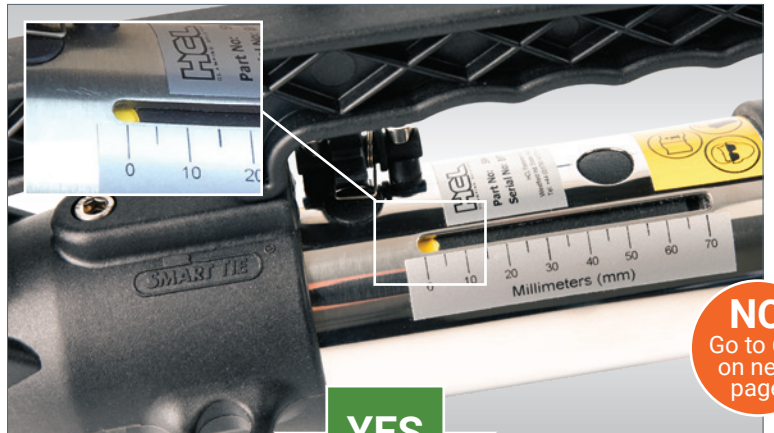

NO
Go to 6.1
on next
page

YES

7

Insert tool onto band...
...and push tool up against buckle

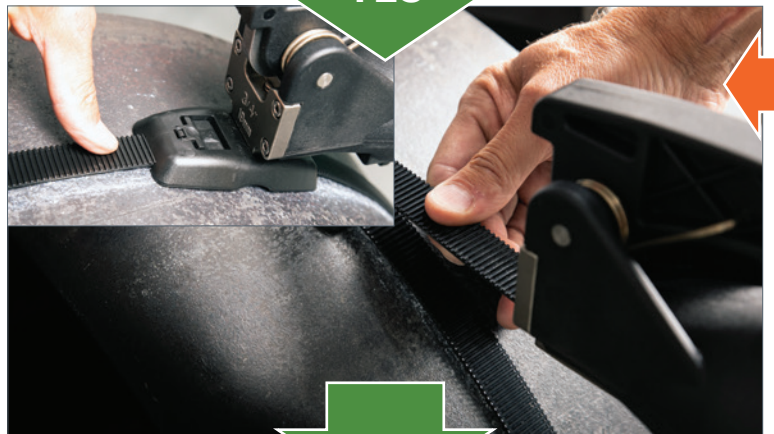

NOTE – The Mountz torque wrench is factory set to the correct torque requirement for the specified product being used. The set torque is marked on the wrench.

The torque wrench does not have a ratchet facility and will wind clockwise until the set torque is reached. At this point it will slip over with a positive click.

8

Tighten the band using a winding movement...
...until the Torque wrench 'CLICKS'



CLICK!

YES
Go to 8.1
on next
page

NO

9

Is the yellow marker in the '70mm' position
(tool has run out of movement)?



3.1

6.1

...wind Torque wrench anti-clockwise...



Go to 7
on previous
page

6.2

...until the yellow marker is at the
'0mm' position...

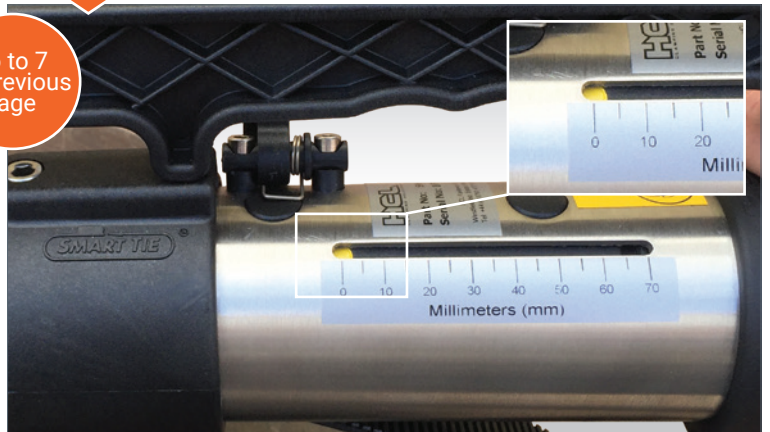

8.2

...until the yellow marker is at the
'0mm' position...



Go to 8
on previous
page

8.1

...wind Torque wrench anti-clockwise...



NOTE – In the anti-clockwise direction, the torque wrench will click over if enough resistance is met. This could be experienced if the tool is forced when reaching the end of its travel at the '0mm' position.



Operation – Using the Tool with Norbar Torque Wrench

IMPORTANT – If Norbar type torque wrench is being utilised follow steps 10-20 and refer to the torque setting section.

10

Wrap band around the application...
...and insert band into other end of buckle



11

Pull band tight by hand, making sure teeth are fully engaged with band



12

Set Torque Wrench to the required Torque

Refer to the tensioning tables in the torque setting section for the maximum recommended torque. See torque wrench manual for detailed operating instructions. For reference the maximum torque settings for each material are labelled on the tool and torque wrench.



WARNING – Do not exceed the maximum torque settings recommended for the Smart® Tie or Smart® Band system being applied

13

Attach Torque wrench to the square drive at the rear of the tool.

Optional – Lock Torque wrench to square drive using a 4mm hexagon key

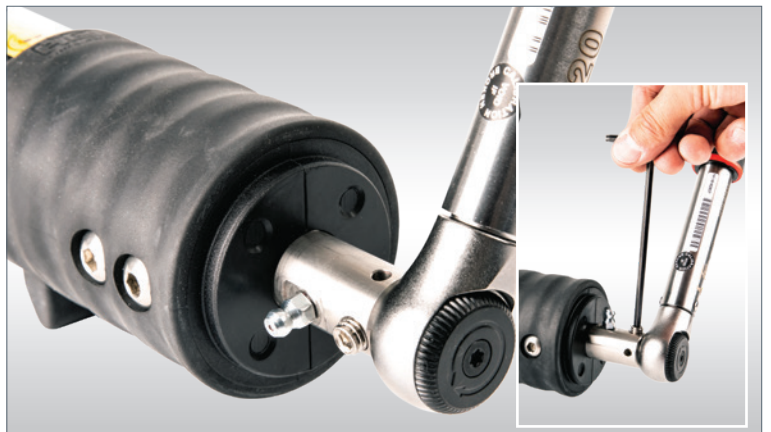

3.1

Operation - Using the Tool with Norbar Torque Wrench

14

Is yellow marker in the '0mm' position?



NO
Go to 14.1
on next
page

YES

15

Insert tool onto band...
...and push tool up against buckle

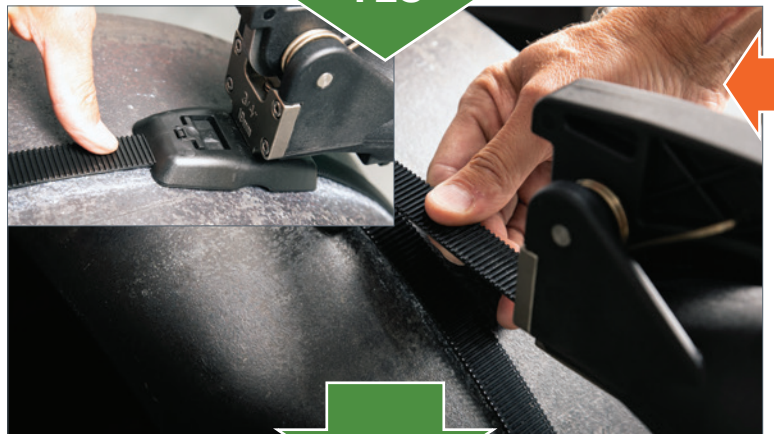

16

Tighten the band using a ratcheting
movement...
...until the Torque wrench 'CLICKS'

WARNING – Do not wind the Torque wrench
using a smooth continuous movement or
beyond the click point



17

Is the yellow marker in the '70mm' position
(tool has run out of movement)?



YES
Go to 17.1
on next
page

NO

3.1

14.1

...wind Torque wrench anti-clockwise...



Go to 14
on previous
page

14.2

...until the yellow marker is at the
'0mm' position...

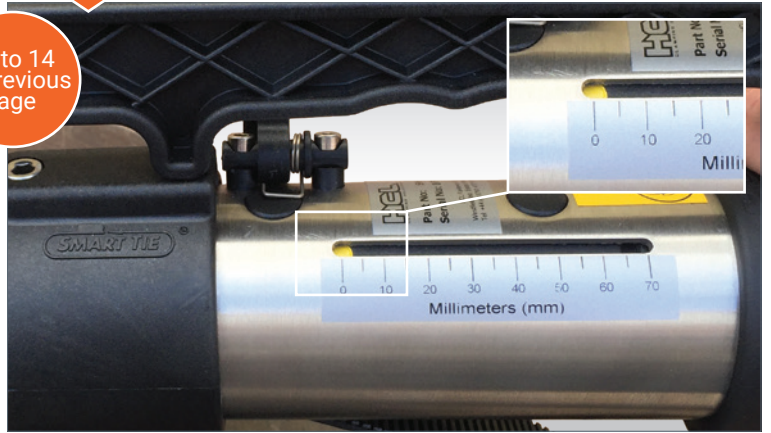

17.2

...until the yellow marker is at the
'0mm' position...



Go to 16
on previous
page

17.1

...wind Torque wrench anti-clockwise...



Operation - Using the Tool

18

Continue anti-clockwise rotation until the yellow marker is in the '0mm' position. At this point the cutting clasp will release the cutting handle.



19

To remove the excess band, simply take hold of the cutting handle...

...and push upwards



20

Once cut, remove tool from buckle

Installation is now complete



Torque Setting – Smart® Band Hybrid & Compact

Note – This section is only required if the Norbar torque wrench is being utilised.

WARNING – The SM-FT-1000 tool range is not suitable for Smart® Band Standard systems. Do not exceed the maximum torque settings recommended for the Smart® Tie or Smart® Band system being applied



Recommended Torque Settings

***IMPORTANT –** From July 2019 a new low torque drive system has been incorporated into the tool giving lower torque settings than previous tools*

Smart® Tie		Diameter	Max Input Torque ¹		Max System Force (During Tightening)			Min Retention Force (After Tightening)		
Size	Material	mm	Nm	lb-ft	N	kgf	lbf	N	kgf	lbf
20mm (¾")	PA66 (Nylon 6.6)	100	5.5	4.1	3600	367	809	1500	153	337
	PA12 (Nylon 12)		4	3.0	3000	306	674	1100	112	247
	PK		5	3.7	3600	367	809	1500	153	337
	PPS		5	3.7	3400	347	764	1500	153	337
32mm (1¼")	PA66 (Nylon 6.6)	200	TBC	TBC	TBC	TBC	TBC	TBC	TBC	TBC
	PA12 (Nylon 12)		8	6.0	6000	612	1349	2500	255	562
	PK		11	8.1	7000	714	1574	4000	408	899
	PPS		8	6.0	5500	561	1236	2000	204	450

Smart® Band Hybrid & Smart® Band Compact			Diameter	Max Input Torque ¹		Max System Force (During Tightening)			Min Retention Force (After Tightening)		
Size	Buckle Material	Band Material	mm	Nm	lb-ft	N	kgf	lbf	N	kgf	lbf
19mm (¾")	PA66 (Nylon 6.6.)	PA66 (Nylon 6.6.)	600	7	5.2	6000	612	1349	2500	255	562
	PA12GF (Nylon 12 Glass-filled)	PA12GF (Nylon 12 Glass-filled)		8	5.9	7000	714	1574	3500	357	787
	PPS	PPS		8	5.9	7000	714	1574	3500	357	787
	POM (Acetal)	POM (Acetal)		7	5.2	6000	612	1349	2500	255	562
32mm (1¼")	PA66 (Nylon 6.6.)	PA66 (Nylon 6.6.)	600	14	10.3	14000	1428	3147	7000	714	1574
	PA12GF (Nylon 12 Glass-filled)	PA12GF (Nylon 12 Glass-filled)		14	10.3	14000	1428	3147	7000	714	1574
	PPS	PPS		14	10.3	12000	1224	2698	7000	714	1574
	POM (Acetal)	POM (Acetal)		10	7.4	10000	1020	2248	5000	510	1124

¹ The input torque in the table above is the maximum recommended torque around a cylindrical application. This may need to be reduced depending on the following:

- An irregular shaped application, e.g. an application that has sharp corners around its profile
- An application in high ambient temperatures and direct sunlight, where the temperature of the Smart® Band or Smart® Tie exceeds 40°C
- An application where the Smart® Band buckle is suspended in mid-air, i.e the buckle is not supported underneath

Servicing

NOTE – It is advised that a full service is carried out after every 1000 straps or every year, whichever ever is soonest

1

Wind the square drive clockwise until yellow marker is in the '70mm' position

2

Tap square drive on rear of tool to ensure rear housing is as far forward as possible (this will aid the removal of the bolts)

3

Remove M8 Buttonhead screws (4x) using 5mm hexagon key

4

Remove internal sub-assembly

5

Wind the square drive anti-clockwise to remove threaded shaft from internal housing.

Thoroughly clean all parts.

Apply a general grease suitable for water contact to male and female threads as shown

6

Remove M4 Capscrews and Full nuts (4x each) from split housing. Thoroughly clean all parts

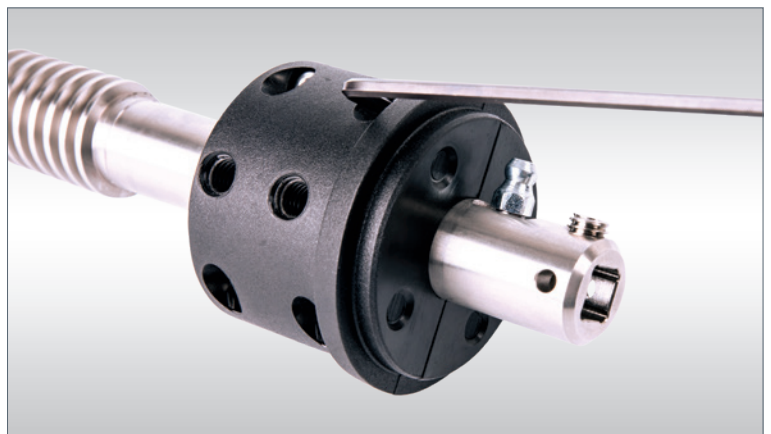
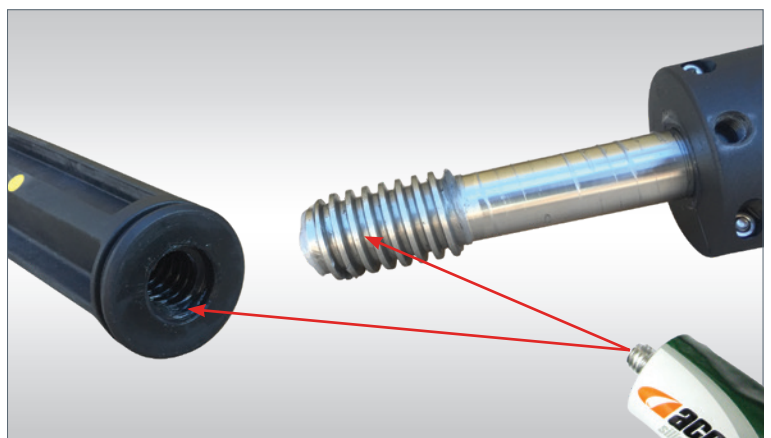
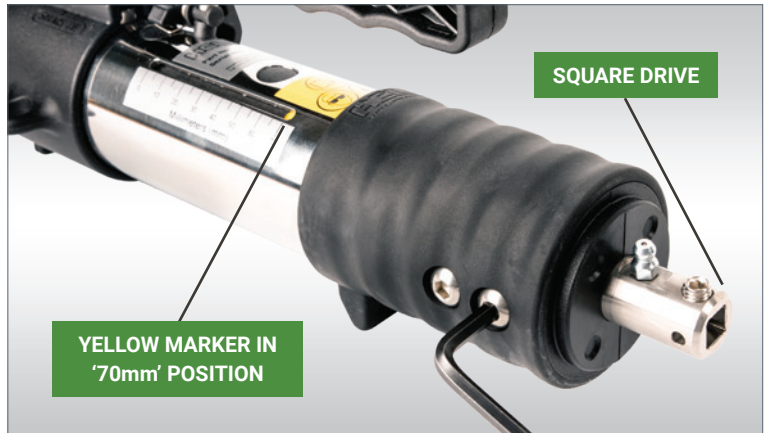

7

Apply a general grease suitable for water contact to thrust washers and split housing as shown

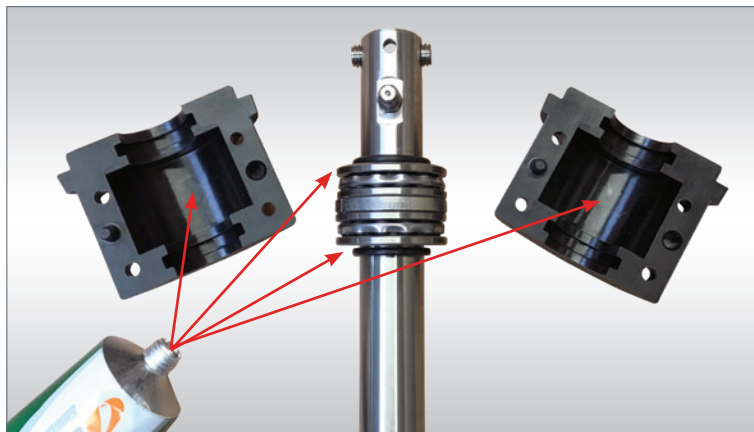

8

Change the Pawl and Blade by firstly removing the Pin from the Pawl housing



9

Remove the Pawl assembly and spring

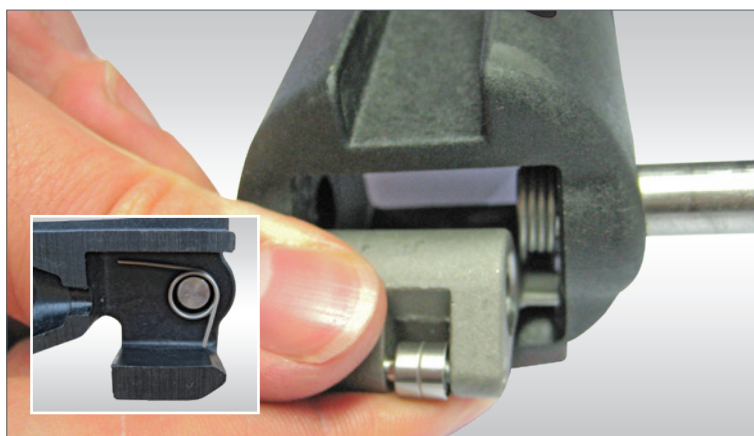

NOTE – Take care to note the orientation of the spring for reinsertion

10

Reassemble Pawl Housing as reverse of disassembly



11

To take off the cutting blade housing, remove M6 Capscrew and slide front assembly off main body. Thoroughly clean all parts



12

Ensure cutting handle is in the down position. Remove Capscrews (4x) using 3mm hexagon key and remove old front plate

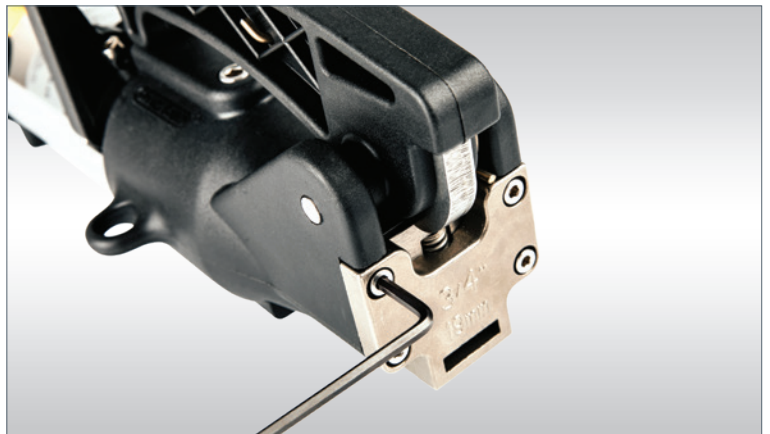

13

Remove existing blade and insert spring into new blade. Grease Cam and Blade as shown

WARNING – Care must be taken when handling the sharp blade to avoid injury



14

Reassemble tool as reverse of disassembly

15

If the tool has been used subsea it is advised that it is immediately washed thoroughly by immersing in clean fresh water. A full service is advised in this situation. However, if this is not possible the main thread can be lubricated via the grease nipple located on the main shaft at the rear of the tool

NOTE – Never store the tool wet

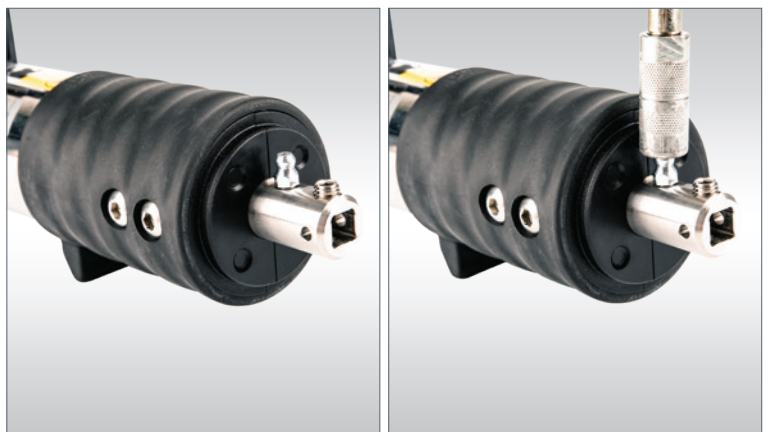

Servicing - Troubleshooting

Symptom 1: Smart® Band or Smart® Tie failure during fitting

Failure Mode & Possible Cause	Solution
1. System breaks due to cutting whilst in tension (yellow marker not in '0mm' position)	Do not operate cutter during tightening (Refer to Section 2.1, steps 12-14)
2. Band/Buckle breaks due to incorrect input torque	Set correct input torque (Refer to Section 2.2, Tensioning Tables)
3. Buckle breaks due to incorrect tool positioning during fitting	Ensure tool is correctly positioned in buckle. Do not lift tool away from application during tightening (Refer to Section 2.1, steps 8-9)
4. Band breaks due to repeated relaxing and re-tightening	Only tighten the band once (Refer to Section 2.1, step 10)
5. Band pulls out of fixed end of buckle	Ensure that latch is fully engaged with band before tensioning (Refer to Section 2.1, step 2)
6. Buckle breaks due to being positioned in mid-air or around too small a radius	Position Buckle on suitable radius (Refer to Banding Products Technical Booklet). Reduce the input torque if re-positioning is not possible
7. Band breaks due to being positioned around too small a radius	Position Buckle on suitable radius (Refer to Banding Products Technical Booklet). Reduce the input torque if re-positioning is not possible

Symptom 2: Inadequate Smart® Band or Smart® Tie tension

Possible Cause	Solution
1. Tool has hit rear stop (yellow marker in '70mm' position)	Wind square drive anti-clockwise until yellow marker is in '0mm' position. Then continue tightening the band (Refer to Section 2.1, step 11). Then continue tightening the band until the Torque wrench 'CLICKS'
2. Input torque incorrect	Set Torque Wrench to correct torque (Refer to Section 2.2, Tensioning Tables)
3. Tool requires servicing	Service fitting tool (Refer to Section 4.1, steps 1-9)
4. Tool under performing (lack of tension) after subsea use	Clean & lubricate tool (Refer to Section 4.1)

Symptom 3: Tool does not grip Smart® Band or Smart® Tie

Possible Cause	Solution
1. Excess band tail too short	Remove band and replace with a longer length
2. Pawl housing not fully forward (yellow marker not in '0mm' position)	Wind square drive anti-clockwise until yellow marker is in '0mm' position (Refer to Section 2.1, step 11)
3. Pawl teeth dirty or clogged	Remove internal sub-assembly from tool and clean pawl teeth (Refer to Section 4.1, steps 1-4)
4. Incorrect pawl fitted	Remove pawl and replace with correct size for band (Refer to Section 3.1, steps 1-3)
5. Pawl stuck in position	Remove internal sub-assembly from tool and un-stick pawl (Refer to Section 4.1, steps 1-4). Clean and re-grease pawl and ensure free movement

Symptom 4: Smart® Band or Smart® Tie does not feed through tool

Possible Cause	Solution
1. Blockage in tool, e.g. band	Remove internal sub-assembly or front sub-assembly as required, then clear blockage (Refer to Section 4.1, steps 1-4)
2. Pawl stuck in position	Remove internal sub-assembly from tool and un-stick pawl (Refer to Section 4.1, steps 1-4). Clean and re-grease pawl and ensure free movement
3. Pawl Housing not fully forward (green marker not showing)	Wind square drive anti-clockwise until yellow marker is in '0mm' position (Refer to Section 2.1, step 11)
4. Blade stuck down	Remove and clean blade. Front end may need to be removed. Be careful that blade does not spring out (Refer to Section 3.2, steps 1-3)
5. Incorrect front end is fitted	Remove front end and replace with correct one (Refer to Section 3.2, steps 1-3)

Symptom 5: Tool does not cut or it is too difficult to cut

Possible Cause	Solution
1. Blockage in tool, e.g. band	Remove blade and/or front end as required, then clear blockage (Refer to Section 3.2, steps 1-3)
2. Cam not lubricated (blade may also make 'screeching' noise)	Grease cam and blade (Refer to Section 4.1, step 9)
3. Blade worn or damaged	Replace or re-sharpen blade (Refer to Section 3.2, steps 1-3)
4. Incorrect blade or front end is fitted	Remove blade and/or front end and replace with correct size for band (Refer to Section 3.2, steps 1-3)

Servicing - Parts List

ITEM	PART NUMBER	DESCRIPTION	QTY.
1	PRT1002	HOUSING, MAIN BODY	1
2	PRT1003	GRIP, OVERMOULDED, FITTING TOOL	1
3	PRT1004	GUIDE	1
4	NUT_NYLOC_HEX_M6_SS	NUT, NYLOC, HEXAGON, M6, SS	2
5	CPS_M6X10_SS	CAPSCREW, SKT HD, M6x10LG, SS	1
6	PRT1341	SPACER, PIVOT PIN PROTOTYPE	2
7	PRT1340	PIN, PIVOT	1
8	PRT1339	CLASP, CUT PREVENTION	1
9	PRT1342	SPRING, TORSION	1
10	CPS_M4X12_SS	CAPSCREW, SKT HD, M4x12LG, SS	2
11	PRT1035	HOUSING, PAWL	1
12*	PRT1036	PAWL, 32mm	1
12*	PRT1055	PAWL 19mm SMART BAND	1
12*	PRT1297	PAWL 20mm SMART TIE	1
12*	PRT1338	PAWL 32mm SMART TIE	1
13	PRT1037	PIN, Ø10x54LG	1
14	PRT1038	PIN, Ø3x20LG	1
15	PRT1039	SPRING, TORSION	1
16	PRT1502	BEARING	1
17	PRT1041	MAIN SHAFT, THREADED	1
18	THB_20_35_10_SS	BEARING, THRUST, BALL, 20IDx35ODx10LG	2
19	PRT1058	WASHER, FLAT, 12IDx35ODx4LG	2
20	WAS_WAVE_2670_3432_124	WASHER, WAVE SPRING, 26.70IDx34.32ODx1.24LG	1

ITEM	PART NUMBER	DESCRIPTION	QTY.
21	PRT1045	HOUSING, THRUST BEARING	2
22	NUT_HEX_M4_SS	NUT, FULL, HEXAGON, M4, SS	4
23	CPS_M4X16_SS	CAPSCREW, SKT HD, M4x16LG, SS	4
24	ORG_01872X262_BS116_N70A	O-RING, BS116, 18.72IDx2.62CS, NITRILE 70A	2
25	SSS_M8X8_CUP_SS	SKT SETSCREW, M8x8LG, CUP POINT, SS	2
26	GN_M6_STRAIGHT_SS	GREASE NIPPLE, STRAIGHT, SS	1
27	PRT1046	HOUSING, CUTTING BLADE	1
28	PRT1295	FRONT END, CAST, 32mm, CHAMFERED SLOT	1
28	PRT1296	FRONT END, CAST, 19mm & 20mm	1
29	CPS_M4X16_SS	CAPSCREW, SKT HD, M4x16LG, SS	4
30	PRT1048	BLADE, CUTTING, 32mm	1
30	PRT1057	BLADE, CUTTING 19mm & 20mm	1
31	PRT1049	SPRING, COMPRESSION	1
32	PRT1050	LEVER, CUTTING MECHANISM	1
33	PRT1051	CAM, ROLLER	1
34	PRT1052	PIN, Ø8x55LG	1
35	PRT1503	HANDLE RETURN SPRING	1
36	BHS_M8X10_SS	BUTTONHEAD SCREW, SKT HD, M8x10LG, SS	4
37	CPS_M6X16_SS	CAPSCREW, SKT HD, M6x16LG, SS	1

*Item 12 is either Smart® Tie 20mm (¾"), Smart® Tie 32mm (1¼"), Smart® Band 19mm (¾") or Smart® Band 32mm (1¼") option.

Items 28 & 30 are either 19mm or 32mm options (20mm Smart® Tie tool uses 19mm option).

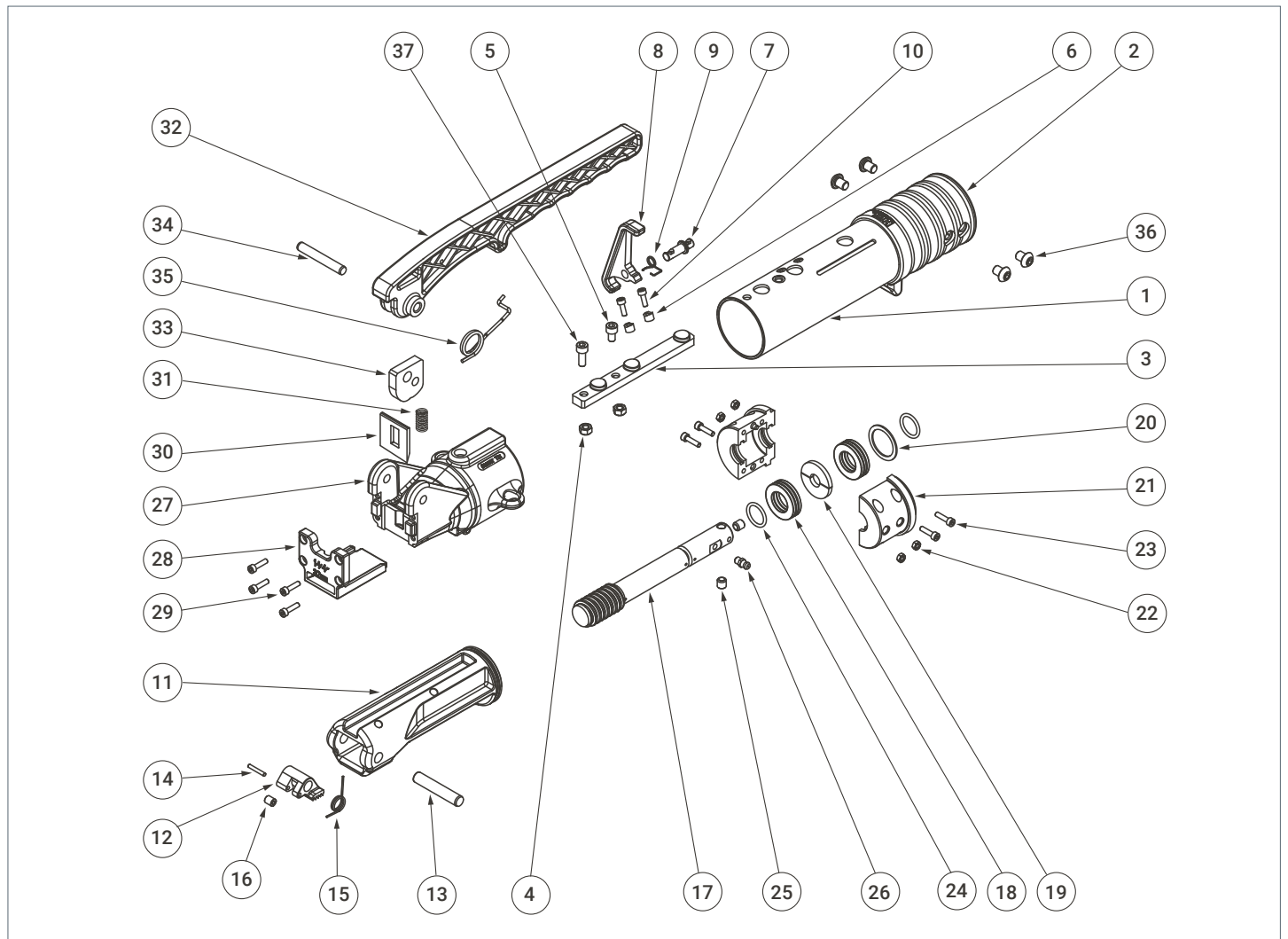

Name of manufacturer: HCL Fasteners Ltd

Address of manufacturer: Clamping House, First Avenue, Westfield Industrial Estate, Radstock,
Bath BA3 4BS, UK

Telephone: +44 (0)1761 417714

Email: sales@hcl-clamping.co.uk

Machinery description: Banding tool for tensioning the HCL Smart® Tie 20mm (¾"),
Smart® Tie 32mm (1¼"), Smart® Band 19mm (¾") Hybrid & Compact or
Smart® Band 32mm (1¼") Hybrid & Compact Systems

Tool Size:

- Smart® Tie 20mm (¾")
- Smart® Tie 32mm (1¼")
- Smart® Band 19mm (¾") Hybrid & Compact
- Smart® Band 32 mm (1¼") Hybrid & Compact

Serial No:

Considerable effort has been made to ensure that this product conforms to our high quality standards. However, should you experience any difficulties, please contact your Sales representative providing samples and the serial code specified on the tool.

HCL – UK & Rest of the World
Tel: +44 (0)1761 417714
Fax: +44 (0)1761 417710
Email: sales@hcl-clamping.co.uk

HCL – North America
Tel: +1 281-717-1145
Fax: +1 281-717-1146
Email: sales@hcl-clamping.com

Visit www.hclfasteners.com to view our complete range of products.

March 2021

