

Smart Products

Technical Booklet

Smart® Band | Smart® Tie | Smart® Protector | Smart® Installation Tools



Smart® Products – Technical

The following booklet gives technical information relating to the use of HCL **Smart®** products in downhole and drilling applications.

Please note that HCL are committed to an ongoing test program for all products and issue updated versions of this Technical Booklet from time to time. Please refer to the website or contact HCL directly for the latest version. Should you require any information outside the scope of this booklet, please contact HCL directly.

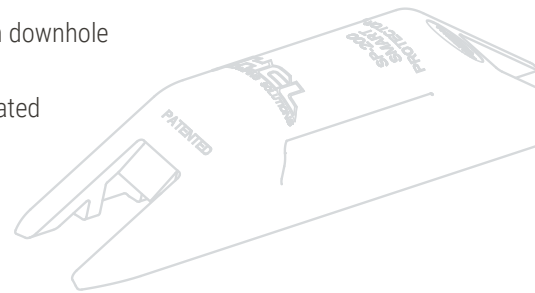

1] Smart® Product Guide

- 1.1] Banding Choice
- 1.2] Smart® Protector Choice
- 1.3] Application
- 1.4] Material Choice

Technical

2] Dimensions and Weights

- 2.1] Smart® Tie Dimensions and Weights
- 2.2] Smart® Band Dimensions and Weights
- 2.3] Smart® Band Compact Dimensions and Weights
- 2.4] Smart® Protector Dimensions and Weights

Installation

3] Design Guidelines

- 3.1] Buckle Location
- 3.2] Recess Dimensions
- 3.3] Smart® Protector Location
- 3.4] Downhole Snagging Prevention

4] Fitting Tools

- 4.1] SM-FT-2000
- 4.2] SM-FT-1000 Supplied with torque wrench
- 4.3] SM-FT-3000 Pneumatic
- 4.4] SM-FT-3000 Pneumatic Durability

Performance

5] Tensile Strength

- 5.1] System Tensile Tests – Introduction
- 5.2] Smart® Tie System Tensile Tests
- 5.3] Smart® Band System Tensile Tests – Standard Buckle
- 5.4] Smart® Band System Tensile Tests – Hybrid Buckle
- 5.5] Smart® Band Compact – System Tensile Tests

6] Creep and Stress Relaxation

- 6.1] Stress Relaxation

7] Axial Retention

- 7.1] Banding Axial Retention
- 7.2] Banding and Smart® Protector Assembly Axial Retention

8] Roller Testing

9] Impact Strength

- 9.1] Smart® Band Impact Strength
- 9.2] Smart® Protector Impact Strength

10] Half Shell Minimum Bending Radius

11] Piggyback Pipe Lay

- 11.1] Smart® Band Piggyback Performance

12] Hydrostatic Compression

- 12.1] Typical Hydrostatic Compression Test Simulation

13] Abrasion

- 13.1] Polymer Abrasion Comparison
- 13.2] Downhole Smart® Protector Abrasion
- 13.3] Concrete Surfaces

14] Marine Growth

Material

15] Temperature Resistance and Flammability

16] Material Properties

- 16.1] Polymer Mechanical Properties
- 16.2] Glass Fibre Yarn – Ø1mm Material Properties

17] Chemical Resistance

- 17.1] Chemical Resistance Overview
- 17.2] Permeability
- 17.3] Chemical Resistance Chart

18] Ageing

- 18.1] Ageing in Water (pH7)
- 18.2] Hot Ageing in Air
- 18.3] Fresh Water Immersion
- 18.4] Oil Immersion – (Mineral Oil – Isovoltime at 110°C)
- 18.5] CO₂ (Carbon Dioxide) and H₂S (Hydrogen Sulphide) and NORSOK M-710

19] Weathering

- 19.1] PA66
- 19.2] POM (Acetal)
- 19.3] Weathering Comparison for PA12 and PA11
- 19.4] PK
- 19.5] PPS
- 19.6] PEEK

20] Well Flushing

- 20.1] Advantages of Polymer Products

Quality

21] Quality

- 21.1] Test Validation
- 21.2] Quality Control



HCL Ltd are accredited to the BS EN ISO9001-2015 quality standard. Products are designed and tested in line with controlled guidelines as stated within the HCL Quality Manual.



SGS

Where applicable product testing has been witnessed and approved by SGS Verification Services.



This section gives guidance when choosing the right Smart® product for your application. The following factors should be taken into consideration:

- Temperature
- Chemical resistance
- Weathering
- Toughness
- Cost
- Flammability
- Axial retention required
- Tensile strength & weight of cable
- Cable size
- Pipe OD and casing ID

If there is any doubt about the polymer choice and use of the product in a downhole or subsea application then trials should be carried out to ensure suitability.

For further guidance and advice contact HCL.



Smart® Protector

Smart® Tie

Smart® Band Compact

Smart® Band

1.1] Banding Choice

The following table provides a simple overview of available Smart® products, their size and material variations. Fitting tools that compliment each product are listed for reference.

*Please note. Figures stated are for material in the Dry As Moulded (DAM) State. Tests are carried out around steel half shells and recorded using Tensile test equipment.

Banding Product	Size Options	Band Dimensions			Material Options		System Strength*	Fitting Tool Options
		Nominal Length mm [m] {Ft}	Width mm (inches)	Thickness mm (inches)	Buckle	Band		
Smart® Tie	20mm (¾")	450	20 (0.79)	3.6 (0.14)	PA66	PA66	4976 (508) [1119]	SM-FT-1000-20ST SM-FT-2000-19 SM-FT-3000-20ST
		600			PA12		4048 (413) [910]	
		750			PK		5913 (603) [1329]	
					PPS		5023 (512) [1129]	
Smart® Tie	32mm (1¼")	550	32 (1.26)	4.6 (0.18)	PA12	PA66	9306 (949) [2092]	SM-FT-1000-32ST SM-FT-2000-32 SM-FT-3000-32ST
		850			PK		12536 (1279) [2818]	
Smart® Band Standard	7mm (¼")	{30} {100} {225} {738}	7.0 (0.28)	2.8 (0.11)	PA66	PA66	1744 (178) [392]	SM-TA-528A
	10mm (¾")	{30} {100} {125} {410}	9.8 (0.39)	3.6 (0.14)	PA66	PA66	3002 (306) [675]	SM-TA-528A
	19mm (¾")	{30} {100} {60} {200}	19.2 (0.76)	3.6 (0.14)	PA66	PA66	4086 (417) [919]	
Smart® Band Hybrid	19mm (¾")	{30} {100} {60} {200}	19.2 (0.76)	3.6 (0.14)	PA66	POM	3002 (306) [675]	SM-FT-1000-19 SM-FT-2000-19
					PA66	PA66	13190 (1345) [2965]	
					POM	POM	11010 (1123) [2475]	SM-FT-2000-19 SM-FT-3000-19
					PA12GF	PA12GF	12950 (1321) [2911]	
Smart® Band Hybrid	32mm (1¼")	{30} {100}	32.2 (1.27)	4.7 (0.19)	POM	PA66	17380 (1773) [3907]	SM-FT-1000-32 SM-FT-2000-32 SM-FT-3000-32
					PA12GF	PA12GF	23000 (2346) [5170]	
Smart® Band Compact	19mm (¾")	User Defined	19.2 (0.76)	3.6 (0.14)	PA12GF	PA66	15488 (1579) [3482]	SM-FT-1000-19 SM-FT-2000-19 SM-FT-3000-19
					PPS	PPS	11696 (1193) [2629]	
					32mm (1¼")	32.2 (1.27)	4.7 (0.19)	PA12GF
PPS	PPS	22328 (2277) [5020]						

1.2] Smart® Protector Choice

The following table gives measurements for each Smart® Protector to help in choosing the most suitable size for the cable selection.

SP Size	Cable Recess 1	Cable Recess 2	Cable Recess 3
SP-100	1 x ¼"	1 x ⅛"	1 x 2mm
SP-100-2	2 x ¼"		
SP-200	1 x 11mm Square or round (nominal)		
SP-200-3/8	1 x ⅜" Square or round (nominal)		
SP-300	2 x 11mm square or round (nominal)	2 x ¼"	
SP-400-3820	1 x Flat ESP 38mm wide x 20mm height ⁴		
SP-400-5228	1 x Flat ESP 52mm wide x 20mm height ⁴		
SP-500-1721	1 x 17-21mm round		
SP-500-3338	1 x 33-38mm round		

⁴ The dimension for height will be reduced as the pipe diameter reduces due to the outer pipe surface encroaching into the cable recess.

1.3] Application

The following table gives the HCL recommended products and material choice for certain applications based on the latest engineering polymers available. The applications below are just a few of many – Please contact HCL for further information and recommendations for your particular application.

Application	Smart® Tie	Smart® Band	Smart® Protector	Material Choice
GENERAL OUTDOORS				
General fixing e.g. signs	✓	✓	✗	PA66
Cable Management	✓	✓	✓	PA66
Sensor Fixing	✓	✓	✓	PA66
DOWNHOLE				
Downhole clamping and cable protection up to 125°C (257°F)	✓	Compact	✓	PK
Downhole clamping and cable protection up to 175°C (347°F)	✓	Compact	✓	PPS
Downhole clamping and cable protection up to 250°C (482°F)	✗	✗	✓	PEEK
CORROSION				
Pile Wrap – Standard	✗	Hybrid	✗	POM
Pile Wrap – Premium	✗	Hybrid	✗	PA12GF
Sacrificial Anode Clamping	✗	Hybrid/Compact	✓	PA12GF
Impressed Current Cathodic Protection Clamping	✗	Hybrid/Compact	✓	PA12GF
SUBSEA				
Cable Protection	✓	Compact	✗	PK & PA12GF
Piggyback Saddle	✗	Compact	✗	PA12GF
Strakes	✗	Compact	✗	PA12GF
Cable Management	✓	Hybrid/Compact	✓	PK & PA12GF
Sensor Fixing	✓	Hybrid/Compact	✓	PK & PA12GF

1.4] Material Choice

Characteristic	Units	PA66 Polyamide66 (Nylon66)	POM Polyoxymethylene (Acetal)	PA12 Polyamide12 (Nylon12)	PA12GF Polyamide12GF (Nylon12 Glass Filled)	PK Polyketone	PPS PolyPhenylene Sulfide	PEEK Polyetheretherketone	Detailed Section No
Recommended for Downhole Use		✓ ¹	✗	✓	N/A	✓	✓	✓	
Recommended for Subsea Use		✓ ¹	✓	✓	✓	✓	✓ ²	✓ ²	
Maximum Temperature ¹	°C (°F)	125 (257)	95 (203)	100 (212)	100 (212)	125 (257)	175 (347)	250 (482)	15
Flammability	UL94	V-2	HB	HB	HB	HB	V-0	V-0	15
General Chemical Resistance	Scale 1-10	3	3	5	5	7	9	10	17
Sour (CO ₂) & Sweet (H ₂ S) Gas Resistance	Scale 1-10	3	N/A	5	5	7	9	10	17
General Weathering & UV Resistance ³	Scale 1-10	7	7	10	10	4	6	4	19
Strength	Scale 1-10	7 ⁴	5	6	9	8	9	10	5
Toughness	Scale 1-10	8 ⁵	5	9	9	9	5	7	8, 9 & 16
Density	g/cm ³ (oz/inch ³)	1.14 (0.66)	1.41 (0.82)	1.01 (0.58)	1.22 (0.71)	1.24 (0.72)	1.25 (0.72)	1.30 (0.75)	16
Cost (Low to High)	Scale 1-10	2	2	4	4	3	7	10	

¹ Stated temperatures are based on the tensile half-life, e.g. elongation, of the material measured in a controlled environment. Other factors, e.g. the presence of chemicals, may significantly reduce this value.

² Recommended for high temperature subsea applications

³ Applicable to black product

⁴ Strength reduces due to hygroscopic properties if permanently immersed in water

⁵ Toughness increases due to hygroscopic properties if permanently immersed in water

- Where traditionally PA11GF has been used in Smart® Band Subsea applications PA12GF is now the recommended polymer for use in long life subsea applications.
- Where traditionally PA12 has been used in downhole applications PK is now being recommended giving better performance as well as cost effectiveness.
- Where cost is critical PA66 can be used for short term subsea applications but because PA66 is noticeably hygroscopic, tensions will reduce over time in a wet environment.

Conclusion

- As a general point the higher the temperature resistance the better the chemical resistance.

2] Dimensions and Weights

2.1] Smart® Tie Dimensions and Weights

2.1.1] Smart® Tie Dimensions

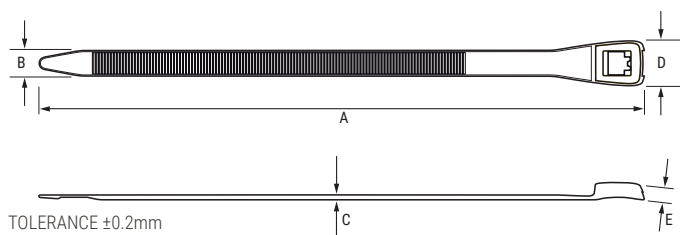

Size	Nominal Length	Maximum Length (A)	Band Width (B)	Band Thickness (C)	Head Width (D)	Head Height (E)
	(mm)	mm (inch)	mm (inch)	mm (inch)	mm (inch)	mm (inch)
20mm (¾")	450	470.0 (18.50)	20.0 (0.79)	3.6 (0.14)	35.0 (1.38)	12.0 (0.47)
	600	620.0 (24.41)				
	750	770.0 (30.31)				
32mm (1¼")	550	573.0 (22.56)	32.0 (1.26)	4.6 (0.18)	50.0 (1.97)	20.0 (0.79)
	850	873.0 (34.37)				

2.1.2] Smart® Tie Weight and Density Table

Size	Nominal Length (mm)	Material	Weight (g (oz))	Average Density* (g/cm ³ (oz/inch ³))
20mm (¾")	450	PA66	39.5 (1.39)	1.15 (0.66)
		PA12	34.6 (1.22)	1.04 (0.60)
		PK	42.4 (1.50)	1.24 (0.71)
		PPS	43.1 (1.52)	1.26 (0.73)
		PA66	49.2 (1.74)	1.15 (0.66)
		PA12	43.1 (1.52)	1.04 (0.60)
	600	PK	52.8 (1.86)	1.24 (0.71)
		PPS	53.7 (1.90)	1.26 (0.73)
		PA66	59.7 (2.11)	1.15 (0.66)
		PA12	52.3 (1.85)	1.04 (0.60)
		PK	65.1 (2.30)	1.24 (0.71)
		PPS	65.1 (2.30)	1.26 (0.73)
750	PA66	96.1 (3.39)	1.15 (0.66)	
	PA12	86.9 (3.07)	1.04 (0.60)	
	PK	103.6 (3.66)	1.24 (0.71)	
	PA66	139.9 (4.94)	1.15 (0.66)	
	PA12	126.5 (4.47)	1.04 (0.60)	
	PK	156.5 (5.52)	1.24 (0.71)	

*Average Density is calculated from the assembled Smart® Tie components. This comprises of the strap and the toothed latch insert.

2.2] Smart® Band Dimensions and Weights

2.2.1] Band Dimensions

TOLERANCE ±0.2mm

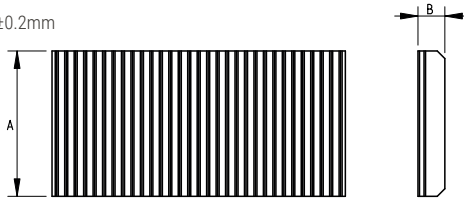

Size	Maximum Width (A)	Maximum Thickness (B)
	mm (inch)	mm (inch)
7mm (¼")	6.9 (0.27)	2.6 (0.10)
10mm (⅜")	9.8 (0.39)	3.6 (0.14)
19mm (¾")	19.2 (0.76)	3.6 (0.14)
32mm (1¼")	32.2 (1.27)	4.7, (0.19)

2.2.2] Band Weight and Density Table

Size	Material	No of Glass Cords	Weight/Length (g/m (oz/ft))	Average Density* (g/cm ³ (oz/inch ³))
7mm (¼")	PA66	3	17 (0.60)	1.14 (0.66)
	PA66	4	30 (0.32)	1.15 (0.66)
10mm (⅜")	PA12	2	28 (0.30)	1.25 (0.72)
	PA66		70 (0.75)	1.23 (0.71)
	POM		80 (0.86)	1.48 (0.86)
19mm (¾")	PA12GF	11	71 (0.77)	1.25 (0.72)
	PPS		73.1 (0.79)	1.25 (0.72)
	PA66		154 (1.66)	1.14 (0.66)
	POM		164 (1.76)	1.33 (0.77)
	PA12GF	21	149 (1.61)	1.20 (0.69)
PPS	160 (1.72)		1.25 (0.72)	

*Average Density is calculated from the combination of the polymer and the glass filled yarn.

2.2.3] Standard Buckle Dimensions

TOLERANCE ±0.2mm



Size	Maximum Height (A)	Maximum Length (B)	Maximum Width (C)
	mm (inch)	mm (inch)	mm (inch)
7mm (¼")	19.2 (0.76)	76.0 (2.99)	15.1 (0.59)
10mm (⅜")	21.5 (0.85)	77.2 (3.04)	22.9 (0.90)

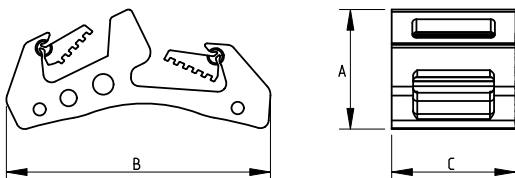

Size	Maximum Height (A)	Maximum Length (B)	Maximum Width (C)
	mm (inch)	mm (inch)	mm (inch)
19mm (¾")	28.3 (1.11)	63.8 (2.51)	30.2 (1.19)

2.2.4] Standard Buckle Weight and Density Table

Size	Material	Weight	Density
		g (oz)	g/cm ³ (oz/inch ³)
7mm (¼")	PA66	7 (0.24)	1.14 (0.66)
10mm (⅜")		12 (0.41)	1.14 (0.66)
19mm (¾")		24 (0.86)	1.14 (0.66)
7mm (¼")	PA12	6.4 (0.23)	1.04 (0.60)
10mm (⅜")		10.9 (0.38)	1.04 (0.60)
19mm (¾")		21.9 (0.77)	1.04 (0.60)

2.2.5] Hybrid Buckle Dimensions

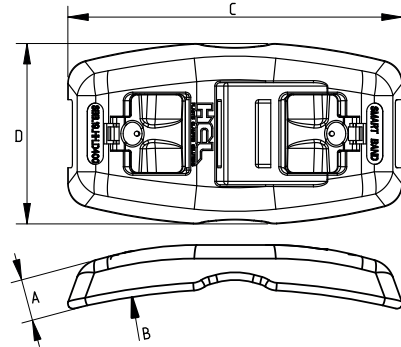

Size	Maximum Height (A)	Radius (B)	Maximum Length (C)	Maximum Width (D)
	mm (inch)	mm (inch)	mm (inch)	mm (inch)
19mm (¾")	12.8 (0.50)	200 (7.87)	99.0 (3.90)	53.0 (2.09)
32mm (1¼")	16.8 (0.66)	300 (11.81)	135.5 (5.33)	76.8 (3.02)

2.2.6] Hybrid Buckle Weight and Density Table

Size	Material	Weight	Average Density*
		g (oz)	g/cm ³ (oz/inch ³)
19mm (¾")	PA66	36 (1.27)	1.20 (0.70)
	POM	41 (1.45)	1.37 (0.79)
	PA12GF	39 (1.38)	1.30 (0.75)
32mm (1¼")	PA66GF	99 (3.49)	1.14 (0.66)
	POM	101 (3.57)	1.36 (0.78)
	PA12GF	95 (3.35)	1.28 (0.74)

*Average Density is calculated from the combination of the latch and the buckle.

2.3] Smart® Band Compact Dimensions and Weights

2.3.1] Smart® Band Compact Dimensions

Note. The Smart® Band Compact incorporates Smart® Band encapsulated within the buckle section. The length options of Smart® Band Compact are variable and can be cut to suit customer specific requirements.

Size	Maximum Height (A)	Maximum Length (B)	Maximum Width (C)
	mm (inch)	mm (inch)	mm (inch)
19mm (¾")	23.4 (0.92)	58.6 (2.31)	37.4 (1.47)
32mm (1¼")	30.0 (1.18)	74.0 (2.91)	51.9 (2.04)

TOLERANCE ±0.2mm

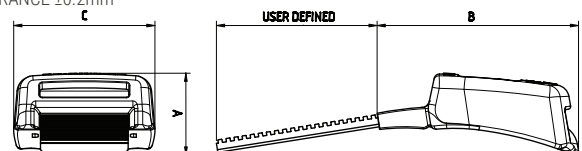

2.3.2] Smart® Band Compact Weight and Density Table

*Weight and Average Density of buckle includes the latch and the integral length of over-moulded band.

Size	Material	Weight Buckle Head*	Weight of Band	Average Density*
		g (oz)	g (oz)	g/cm ³ (oz/inch ³)
19mm (¾")	PA12GF	23.3 (0.82)	Refer to section 2.2.1	1.25 (0.72)
	PA12GF	55.1 (1.94)		1.29 (0.75)
32mm (1¼")	PPS	48.5 (1.71)		1.26 (0.73)

2.3.3] Smart® Band Compact High Load

The Smart® Band Compact High Load is specifically designed to withstand high roller loads in Stinger applications. The rear tab provides support and reduces deformation of the strap as it enters the buckle.

TOLERANCE ±0.2mm

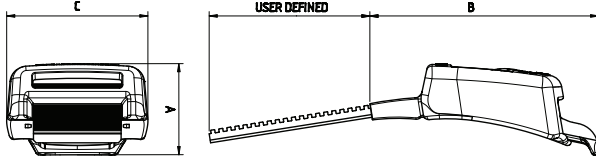

Size	Maximum Height (A)	Maximum Length (B)	Maximum Width (C)
	mm (inch)	mm (inch)	mm (inch)
32mm (1¼")	33.4 (1.31)	84.1 (3.31)	51.9 (2.04)

2.3.4] Smart® Band Compact High Load Weight and Density Table

*Weight and Average Density of buckle includes the latch and the integral length of over-moulded band.

Size	Material	Weight Buckle Head*	Weight of Band	Average Density*
		g (oz)	g (oz)	g/cm ³ (oz/inch ³)
32mm (1¼")	PA12GF	56.9 (2.01)	Refer to section 2.2.1	1.29 (0.75)
	PPS	51.4 (1.83)		1.26 (0.73)

Size	Maximum Width (A)	Maximum Thickness (B)
	mm (inch)	mm (inch)
7mm (¼")	6.9 (0.27)	2.6 (0.10)
10mm (⅜")	9.8 (0.39)	3.6 (0.14)
19mm (¾")	19.2 (0.76)	3.6 (0.14)
32mm (1¼")	32.2 (1.27)	4.7, (0.19)

2.4] Smart® Protector Dimensions and Weights

2.4.1] Smart® Protector SP-100: (Cable Suitability: 1 x ¼" Control Line, 1 x ⅛" Control Line, 1 x 2mm Fibre Optic)

TOLERANCE ±0.2mm

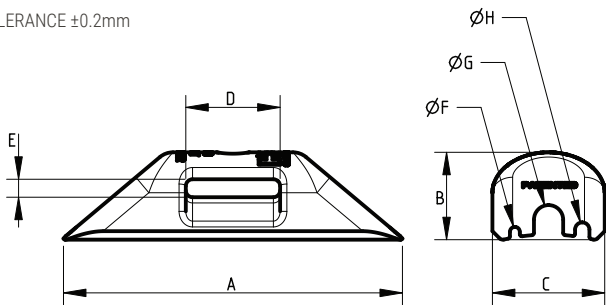

Size	Material	Dimensions (mm)								Weight
		A	B	C	D	E	F	G	H	g (oz)
SP-100	PA66									14.1 (0.50)
	PA12									12.8 (0.45)
	PK	75.5	19.5	25.0	21.0	4.0	Ø2.2	Ø6.5	Ø3.2	15.5 (0.55)
	PPS									15.5 (0.55)
	PEEK									16.1 (0.57)

2.4.2] Smart® Protector SP-100-2: (Cable Suitability: 2 x ¼" Control Lines)

TOLERANCE ±0.2mm

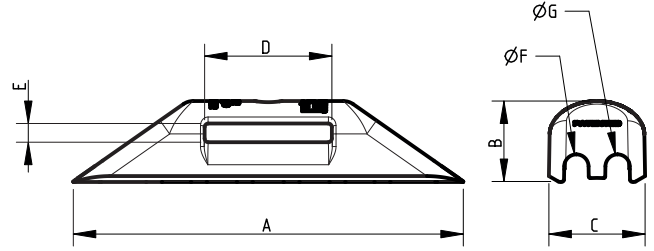

Size	Material	Dimensions (mm)							Weight
		A	B	C	D	E	F	G	g (oz)
SP-100-2	PA66								22.3 (0.79)
	PA12								19.8 (0.70)
	PK	104.0	22.0	25.0	34.0	5.0	6.6	6.6	23.8 (0.84)
	PPS								24.5 (0.86)
	PEEK								25.4 (0.90)

2.4.3] Smart® Protector SP-200: (Cable Suitability: 1 x 11mm Square Encapsulated Line or 1 x 11mm Dia Round Encapsulated Line)

Smart® Protector SP-200-3/8: The Smart® Protector includes a rubber insert strip to accommodate ⅜" square or round encapsulated line.

TOLERANCE ±0.2mm

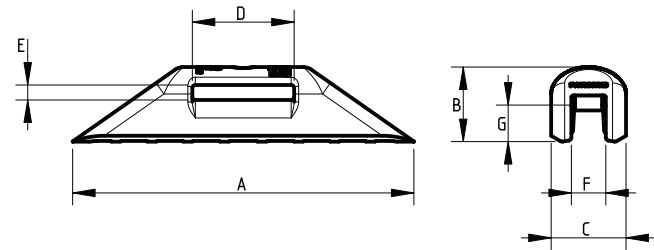

Size	Material	Dimensions (mm)							Weight
		A	B	C	D	E	F	G	g (oz)
SP-200	PA66								21.5 (0.76)
	PA12								19.2 (0.68)
SP-200-3/8	PK	114.0	24.9	25.0	34.0	5.0	11.5	12.2	23.6 (0.83)
	PPS								24.0 (0.85)
	PEEK								24.5 (0.86)

2.4.4] Smart® Protector SP-300: (Cable Suitability: 1 or 2 x 11mm Square or Round Encapsulated Line and/or 1 or 2 x ¼" Control Lines)

TOLERANCE ±0.2mm

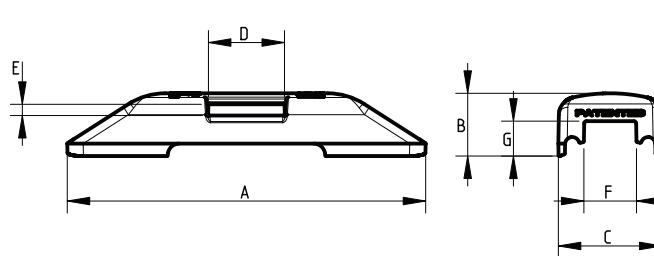

Size	Material	Dimensions (mm)							Weight
		A	B	C	D	E	F	G	g (oz)
SP-300	PA66								43.0 (1.52)
	PA12								38.8 (1.37)
	PK	159.6	27.9	46.2	33.9	5.0	23.4	15.6	47.2 (1.67)
	PPS								47.1 (1.66)
	PEEK								49.0 (1.73)

2.4.5] Smart® Protector SP-400: (Cable Suitability: Flat ESP Cables)

TOLERANCE ±0.2mm

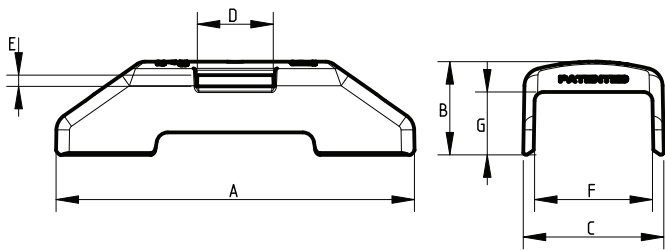

Size	Material	Dimensions (mm)							Weight
		A	B	C	D	E	F	G	g (oz)
SP-400-3820	PA66								44.0 (1.55)
	PA12								39.7 (1.40)
	PK	160.0	32.5	46.2	34.2	5.0	38.1	20.1	48.3 (1.70)
	PPS								48.2 (1.70)
	PEEK								50.2 (1.77)
SP-400-5228	PA66								63.0 (2.22)
	PA12								56.9 (2.01)
	PK	159.6	41.5	62.6	33.8	5.0	52.5	28.0	79.2 (2.44)
	PPS								69.1 (2.44)
	PEEK								71.8 (2.53)

2.4.6] Smart® Protector SP-500: (Cable Suitability: Round Cables)

TOLERANCE ±0.2mm

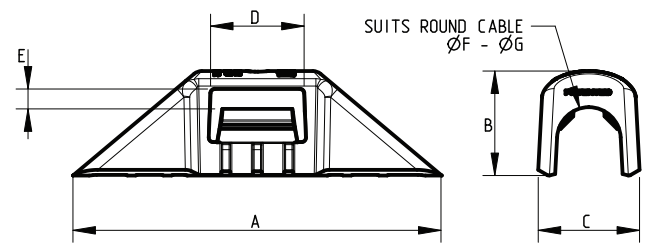

Size	Material	Dimensions (mm)							Weight
		A	B	C	D	E	F	G	g (oz)
SP-500-1721	PA66								29.5 (1.04)
	PA12								26.7 (0.94)
	PK	122.9	34.9	33.8	32.2	6.6	Ø17.0	Ø20.0	32.4 (1.14)
	PPS								32.3 (1.14)
	PEEK								33.6 (1.19)
SP-500-3338	PA66								80.4 (2.84)
	PA12								72.1 (2.54)
	PK	181.0	56.2	55.7	33.5	8.5	Ø33.0	Ø38.0	88.3 (3.11)
	PPS								88.7 (3.13)
	PEEK								92.4 (3.26)

3] Design Guidelines

3.1] Buckle Location

Piggyback Buckle Positions

1. Ideally, the Smart® Band Hybrid, Compact or Smart® Tie buckle should be positioned on a radius; please see 3.2.1 for recommendations. If the buckle must be positioned on a diameter smaller than is recommended, then the banding product may require installation at a reduced tension and the system strength should be expected to be lower than the published values.
2. If it is not possible for the buckle to be positioned on a suitable radius, then the buckle should be positioned on a flat surface. If positioning the buckle on a flat surface, avoid sharp corners near to the buckle (see below); it may also be necessary to reduce the installation tension, and the system strength should be expected to be lower than the published values.
3. Where possible, avoid suspending the buckle in mid-air. If this is unavoidable, then the banding product may require installation at a reduced tension and the system strength should be expected to be lower than the published values.

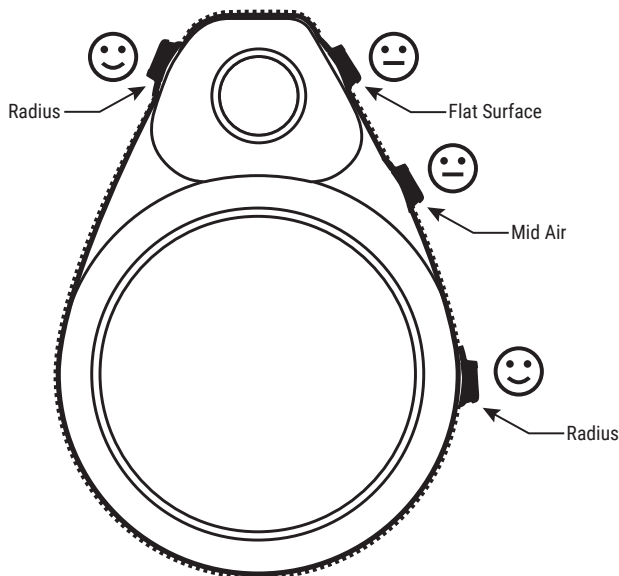

Cable Protection Buckle Position

- Where possible, avoid having a sharp band radius near to the end of the buckle. If this is necessary, e.g. on a smaller diameter application, then the recess length for the buckle (dimension 'D' on the opposite page) should be increased in order to move the sharp band radius away from the buckle. If this is unavoidable, then the banding product may require installation at a reduced tension and the system strength should be expected to be lower than the published values.

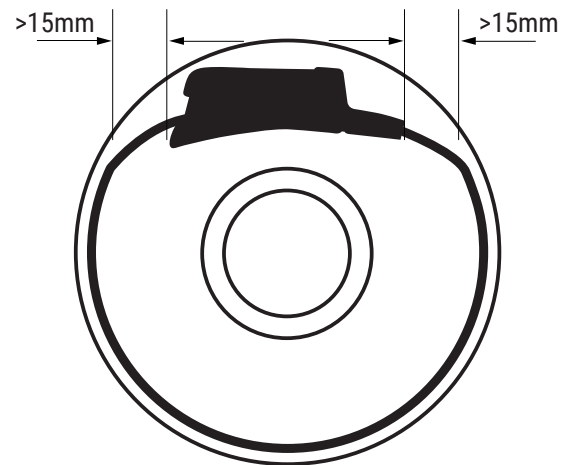

Recommended Minimum Fitting Diameter

For recommended fitting diameter refer to sections 3.2.1 and 3.2.2

3.1.1] Band Profile

DO NOT ALLOW BAND TO PASS OVER 90 DEGREE CORNERS

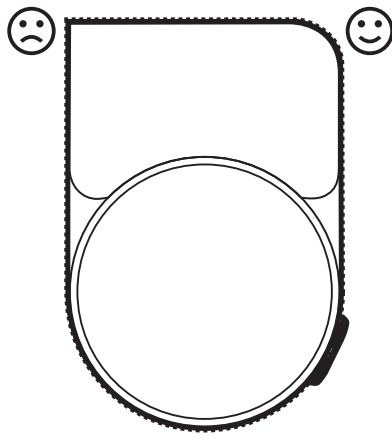

3.2] Recess Dimensions

The following design guidelines for applications utilising Smart® Tie or Smart® Band will ensure maximum performance of the banding product. The underside of the buckles are curved, so it is recommended that the radius on the application is designed to match the radius on the buckle whenever possible. For environments prone to abrasion or impact, it is recommended that the Smart® Band is recessed into the application, in order to give the product greater protection. Certain applications, particularly smaller diameters, may require a special area to be created for the buckle, as shown below to correctly match the underside radius.

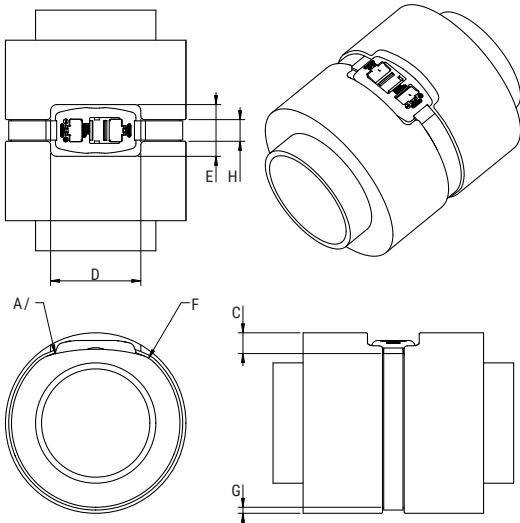

3.2.1] Buckle Recess Dimensions

Product	Size	Recommended Buckle Radius (A)	Minimum Buckle Radius (B)	Minimum Recess Depth (C)	Minimum Recess Length (D)	Minimum Recess Width (E)
		mm (inch)	mm (inch)	mm (inch)	mm (inch)	mm (inch)
Smart® Tie	20mm (¾")	100 (3.94)	30 (1.18)	13 (0.51)	80 (3.15)	39 (1.54)
	32mm (1¼")	100 (3.94)	30 (1.18)	20 (0.78)	100 (3.94)	55 (2.17)
Smart® Band Standard	7mm (¼")	300 (11.81)	50 (1.97)	21 (0.83)	86 (3.39)	19 (0.75)
	10mm (⅜")	300 (11.81)	38 (1.48)	23 (0.91)	88 (3.46)	27 (1.06)
Smart® Band Hybrid	19mm (¾")	100 (3.94)	38 (1.48)	30 (1.18)	75 (2.95)	34 (1.34)
	32mm (1¼")	200 (7.87)	100 (3.94)	14 (0.55)	110 (4.33)	57 (2.24)
Smart® Band Compact	19mm (¾")	300 (11.81)	200 (7.87)	18 (0.71)	145 (5.71)	81 (3.19)
	32mm (1¼")	100 (3.94)	50 (1.97)	18 (0.71)	60 (2.36)	40 (1.57)

3.2.2] Band Recess Dimensions

Product	Size	Minimum Band Radius (F)	Minimum Recess Depth (G)	Minimum Recess Width (H)
		mm (inch)	mm (inch)	mm (inch)
Smart® Tie	20mm (¾")	10 (0.39)	5 (0.20)	22 (0.87)
	32mm (1¼")		6 (0.24)	36 (1.42)
Smart® Band	7mm (¼")		4 (0.16)	9 (0.35)
	10mm (⅜")		5 (0.20)	12 (0.47)
Smart® Band	19mm (¾")	5 (0.20)	22 (0.87)	
	32mm (1¼")	6 (0.24)	36 (1.42)	

3.3] Smart® Protector Location

3.3.1] Smart® Protector Positioning

When specifying Smart® Protector in conjunction with Smart® Band or Smart® Tie, consideration must be given to the position of the buckle in relation to the Smart® Protector. Refer to the illustrations below and Section 3.3.3 Maximum Diameter and Minimum Angle to ensure correct positioning. This will enable the optimum system performance to be achieved.

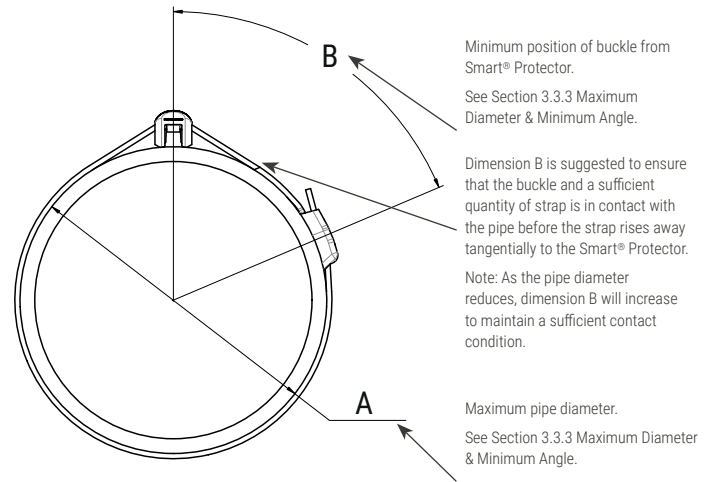

3.3.2] Using Multiple Smart® Protectors

Multiple Smart® Protectors can be used on an application. If utilizing the same style of protector, it is advisable to butt the protectors together to prevent movement in application. If using dissimilar protectors, positioning should ensure that the protectors and the protected cables are adequately secured.

Position additional protectors anti-clockwise from the first unit to ensure sufficient quantity of strap is in contact with the pipe before the strap rises away tangentially to the Smart® Protector.

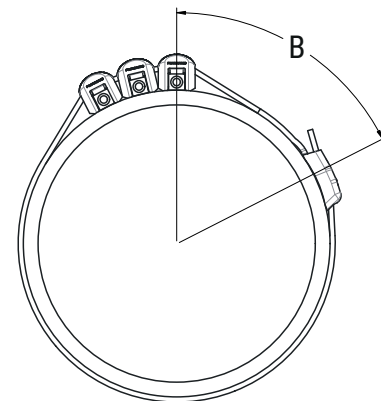

3.3.3] Maximum Diameter and Optimum Angle

When specifying Smart® Protector in conjunction with Smart® Tie, consideration must be given to the following:

1. The pipe diameter onto which the Smart® Protector will be positioned.
2. The type of fitting tool that will be utilized.

Note. The SM-FT-1000 Tool will require a greater tail length of strap through the assembled Smart® Tie to operate compared to the SM-FT-2000 & SM-FT-3000 Tools. See Table.

3.3.3.1] SM-FT-1000

Smart® Protector	Smart® Tie		Maximum Diameter (A) mm (inch)	Minimum Angle (B) Deg
	Size	Length		
		mm		
SP-100	20mm (¾")	450	Ø66 (Ø2.60)	180°
		600	Ø102 (Ø4.02)	105°
		750	Ø183 (Ø7.20)	65°
SP-100-2	20mm (¾")	450	Ø66 (Ø2.60)	180°
		600	Ø102 (Ø4.02)	105°
		750	Ø183 (Ø7.20)	65°
SP-200	32mm (1¼")	550	Ø124 (Ø4.88)	145°
		850	Ø220 (Ø8.66)	120°
		450	Ø63 (Ø2.48)	180°
SP-200-3/8	20mm (¾")	600	Ø100 (Ø3.94)	115°
		750	Ø181 (Ø7.13)	75°
		550	Ø97 (Ø3.82)	145°
SP-300	32mm (1¼")	850	Ø194 (Ø7.64)	105°
		450	Ø61 (Ø2.40)	180°
		600	Ø98 (Ø3.86)	120°
SP-400-3820	20mm (¾")	750	Ø179 (Ø7.05)	85°
		550	Ø94 (Ø3.7)	150°
		850	Ø195 (Ø7.68)	115°
SP-400-5228	32mm (1¼")	450	N/A (N/A)	N/A
		600	Ø96 (Ø3.78)	125°
		750	Ø177 (Ø6.97)	90°
SP-500-1721	32mm (1¼")	550	Ø91 (Ø3.58)	155°
		850	Ø190 (Ø7.48)	120°
		450	N/A (N/A)	N/A
SP-500-3338	20mm (¾")	600	Ø92 (Ø3.62)	145°
		750	Ø172 (Ø6.77)	95°
		550	Ø87 (Ø3.43)	175°
SP-500-1721	32mm (1¼")	850	Ø185 (Ø7.28)	125°
		450	N/A (N/A)	N/A
		600	Ø97 (Ø3.82)	115°
SP-500-3338	20mm (¾")	750	Ø177 (Ø6.97)	80°
		550	Ø93 (Ø3.66)	145°
		850	Ø191 (Ø7.52)	110°
SP-500-3338	32mm (1¼")	450	N/A (N/A)	N/A
		600	Ø137 (Ø5.39)	120°
		750	Ø153 (Ø6.02)	100°
SP-500-3338	32mm (1¼")	550	Ø84 (Ø3.31)	150°
		850	Ø186 (Ø7.32)	130°

3.3.3.2] SM-FT-2000 and SM-FT-3000

Smart® Protector	Smart® Tie		Maximum Diameter (A) mm (inch)	Minimum Angle (B) Deg
	Size	Length		
		mm		
SP-100	20mm (¾")	450	Ø86 (Ø3.39)	130°
		600	Ø123 (Ø4.84)	95°
		750	Ø209 (Ø8.23)	60°
SP-100-2	20mm (¾")	450	Ø86 (Ø3.39)	130°
		600	Ø123 (Ø4.84)	95°
		750	Ø209 (Ø8.23)	60°
SP-200	32mm (1¼")	550	Ø147 (Ø5.79)	135°
		850	Ø243 (Ø9.57)	110°
		450	Ø84 (Ø3.31)	140°
SP-300	20mm (¾")	600	Ø111 (Ø4.37)	105°
		750	Ø208 (Ø8.19)	65°
		550	Ø120 (Ø4.72)	135°
SP-400-3820	32mm (1¼")	850	Ø217 (Ø8.54)	95°
		450	Ø82 (Ø3.23)	155°
		600	Ø119 (Ø4.69)	110°
SP-400-5228	20mm (¾")	750	Ø206 (Ø8.11)	75°
		550	Ø117 (Ø4.61)	140°
		850	Ø214 (Ø8.43)	105°
SP-500-1721	32mm (1¼")	450	Ø80 (Ø3.15)	160°
		600	Ø117 (Ø4.61)	115°
		750	Ø204 (Ø8.03)	80°
SP-500-3338	32mm (1¼")	550	Ø115 (Ø4.53)	145°
		850	Ø212 (Ø8.35)	110°
		450	Ø76 (Ø2.99)	180°
SP-500-3338	20mm (¾")	600	Ø113 (Ø4.45)	135°
		750	Ø199 (Ø7.83)	90°
		550	Ø110 (Ø4.33)	165°
SP-500-3338	32mm (1¼")	850	Ø208 (Ø8.19)	105°

Smart® Protector	Smart® Tie		Maximum Diameter (A) mm (inch)	Minimum Angle (B) Deg
	Size	Length		
		mm		
SP-500-1721	20mm (¾")	450	Ø81 (Ø3.19)	155°
		600	Ø118 (Ø4.65)	105°
		750	Ø205 (Ø8.07)	75°
SP-500-3338	32mm (1¼")	550	Ø116 (Ø4.57)	135°
		850	Ø214 (Ø8.43)	105°
		450	Ø79 (Ø3.11)	180°
SP-500-3338	20mm (¾")	600	Ø165 (Ø6.50)	120°
		750	Ø182 (Ø7.16)	110°
		550	Ø105 (Ø4.13)	100°
SP-500-3338	32mm (1¼")	850	Ø206 (Ø8.11)	75°

3.4] Downhole Snagging Prevention

The base engineering polymers used to create Smart® products have low friction and good abrasion resistant properties.

'Cross Coupling' Cable Protection

'Between Joint' Cable Protection

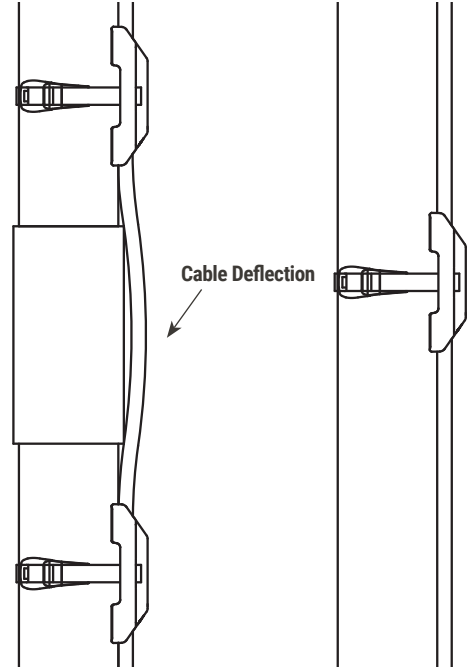

Cross Coupling' Cable Protection

When utilizing the Smart® Protector and Smart® Tie system to secure cable in a cross coupling arrangement, position of the Smart® Protector should be based on the following consideration:

1. The Smart® Protector should be positioned as close to the coupling as possible without causing excessive deflection of the cable over the coupling edge.
2. If the cable is stiff and less flexible the Smart® Protector will need to be positioned further away from the coupling to avoid excessive deflection.



'Between Joint' Cable Protection

The number of Smart® Protector and Smart® Tie systems used to secure cable between joints should be based on the size and weight of the cable. The heavier the cable, the greater number of Smart® Protector and Smart® Tie systems will be required.

Over a 10m joint length based on a light fibre optic cable being secured, a minimum of 3 x Smart® Protector and Smart® Tie systems are advised for cable retention.



Snagged ESP Cable

The image on the right shows the effect of a snagged ESP cable.

The use of the Smart® Protector and Smart® Tie system reduces the chances of snagging in downhole situations.

The shape of the protector assists in riding over any minor obstructions and the flexibility afforded to the positioning of the systems allow the strapped cable to be protected across the coupling and between the joints.

In the unlikely event of a serious collision or failure causing damage or breakage of the system, the polymer construction of the Smart® Protector and Smart® Tie has major advantages over metal strapping when trying to clear accident debris from the downhole environment.

Refer to Section 20, Well Flushing.



4] Fitting Tools

The images below indicate how system force or global strap tension is derived along with a graphical representation of the general force profile during tool tightening, tool release and final retention.

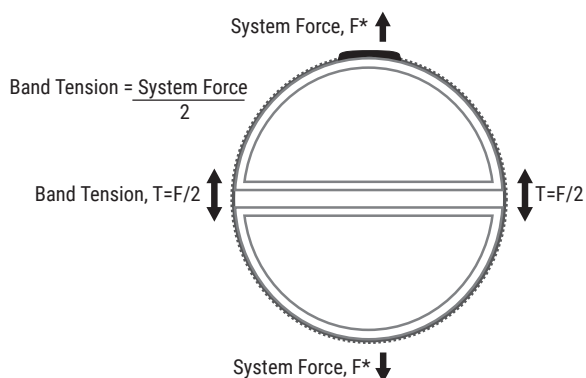

*F= System Force or Global Strap Tension

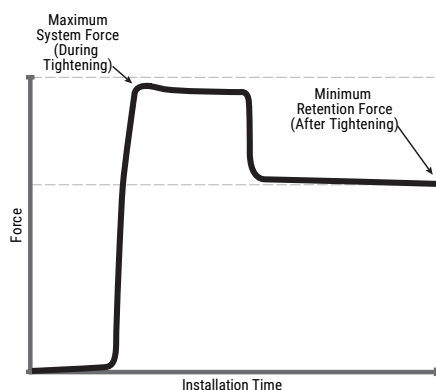

Test Diameters

1. Smart® Tie 19mm tests conducted on 200mm diameter half-shells
2. Smart® Tie 32mm tests conducted on 200mm diameter half-shells
3. Smart® Band 19mm (3/4") tests conducted on 600mm diameter half-shells
4. Smart® Band 32mm (1 1/4") tests conducted on 600mm diameter half-shells

4.1] SM-FT-2000

19mm Smart® Band or 20mm Smart® Tie

DIMENSIONS 370x285x55mm

WEIGHT 0.75kg

32mm Smart® Band or 32mm Smart® Tie

DIMENSIONS 460x377x70mm

WEIGHT 1.33kg

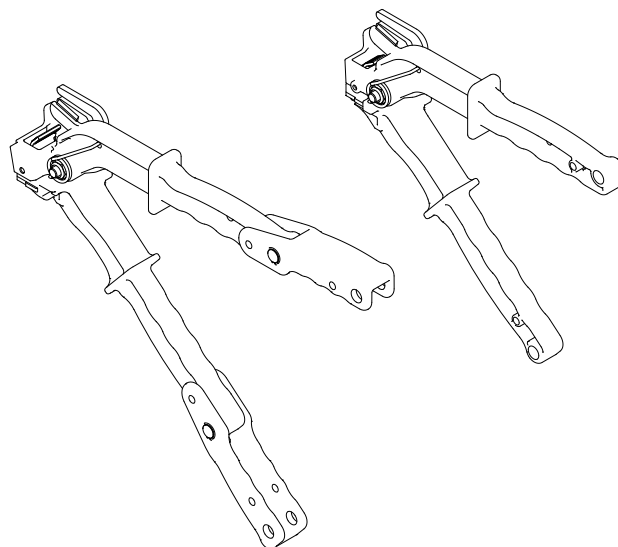

Product	Size	Material	Maximum System Force (During Tightening)	Minimum Retention Force (After Tightening)
			N (kgf) [lbf]	N (kgf) [lbf]
Smart® Tie	20mm (3/4")	PA66	3600 (367) [809]	1500 (153) [337]
		PA12	3000 (306) [674]	1100 (112) [247]
		PK	3600 (367) [809]	1500 (153) [337]
	32mm (1 1/4")	PPS	2800 (286) [629]	1000 (102) [225]
		PA12	6500 (663) [1461]	3500 (357) [787]
		PK	6500 (663) [1461]	3500 (357) [787]

Product	Size	Material	Maximum System Force (During Tightening)	Minimum Retention Force (After Tightening)
			N (kgf) [lbf]	N (kgf) [lbf]
Smart® Band Hybrid and Compact	19mm (¾")	PA66	3500 (357) [787]	2000 (204) [450]
		POM	3500 (357) [787]	2000 (204) [450]
		PA12GF	4500 (459) [1012]	3000 (306) [674]
	32mm (1¼")	PPS	4500 (459) [1012]	3000 (306) [674]
		PA66GF	7000 (714) [1574]	3500 (357) [787]
		POM	7000 (714) [1574]	3500 (357) [787]
		PA12GF	7000 (714) [1574]	3500 (357) [787]
		PPS	7500 (765) [1686]	3500 (357) [787]

IMPORTANT: Figures stated are for tightening using reasonable effort. This will vary from operator to operator.

4.2] SM-FT-1000 Supplied with torque wrench

DIMENSIONS 410x255x135mm

WEIGHT 2.75kg

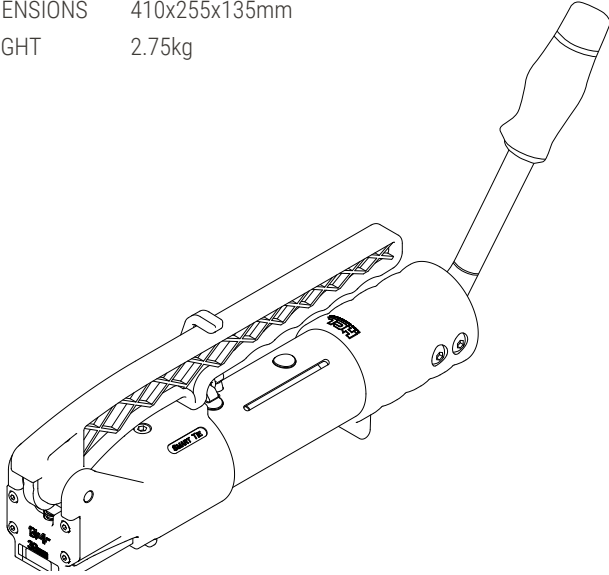

Product	Size	Material	Maximum System Force (During Tightening)	Minimum Retention Force (After Tightening)
			N (kgf) [lbf]	N (kgf) [lbf]
Smart® Tie	20mm (¾")	PA66	3600 (367) [809]	1500 (153) [337]
		PA12	3000 (306) [674]	1100 (112) [247]
		PK	3600 (367) [809]	1500 (153) [337]
	32mm (1¼")	PPS	2800 (286) [629]	1100 (112) [247]
		PA12	6000 (612) [1349]	2500 (255) [562]
		PK	7000 (714) [1574]	4000 (408) [899]
		PPS	5500 (561) [1236]	2000 (204) [450]
Smart® Band Hybrid and Compact	19mm (¾")	PA66	6000 (612) [1349]	2500 (255) [562]
		PA12GF	7000 (714) [1574]	3500 (357) [787]
		PPS	7000 (714) [1574]	3500 (357) [787]
	32mm (1¼")	POM	6000 (612) [1349]	2500 (255) [562]
		PA66	14000 (1428) [3147]	7000 (714) [1574]
		PA12GF	14000 (1428) [3147]	7000 (714) [1574]
		PPS	12000 (1224) [2698]	7000 (714) [1574]
		POM	10000 (1020) [2248]	5000 (510) [1124]

The torque wrench should be operated by employing a ratcheting technique. If the tool is to be used above 40°C, reduce the specified torque by 10%. It is not advisable to use the tool above 60°C.

4.3] SM-FT-3000 Pneumatic

19mm Smart® Band or 20mm Smart® Tie

DIMENSIONS 530x240x130mm

WEIGHT 8.30kg

32mm Smart® Band

DIMENSIONS 600x255x130mm

WEIGHT 7.50kg

32mm Smart® Tie

DIMENSIONS 530x240x130mm

WEIGHT 9.10kg

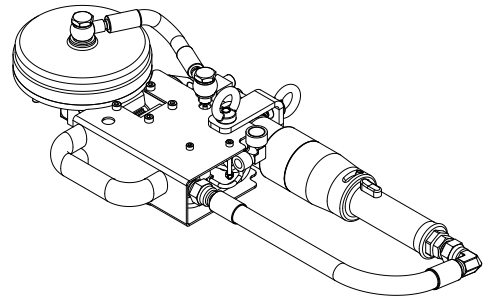

Product	Size	Material	*Maximum System Force (During Tightening)	*Minimum Retention Force (After Tightening)
			N (kgf) [lbf]	N (kgf) [lbf]
Smart® Tie	20mm (¾")	PA66	3800 (388) [854]	1800 (184) [405]
		PA12	3000 (306) [674]	1400 (143) [315]
		PPS	3000 (306) [674]	1400 (143) [315]
	32mm (1¼")	PK	3000 (306) [674]	1500 (153) [337]
		PA12	6000 (612) [1349]	2000 (204) [450]
		PK	7000 (714) [1574]	4000 (408) [899]
Smart® Band Hybrid and Compact	19mm (¾")	PA66	6000 (612) [1349]	3500 (357) [787]
		PA12GF	7500 (765) [1686]	4000 (408) [899]
		POM	6500 (663) [1461]	3500 (357) [787]
	32mm (1¼")	PPS	6500 (663) [1461]	3500 (357) [787]
		PA66	16500 (1683) [3709]	13500 (1377) [3035]
		PA12GF	16500 (1683) [3709]	9000 (918) [2023]
		PPS	16500 (1683) [3709]	9000 (917) [2023]
		POM	12500 (1275) [2810]	7500 (765) [1686]

Final Retention Force may be slightly lower on very small diameters. Final Retention Force will be significantly higher on very large diameters.

*These figures are dependant on the tool being set up in line with the instruction manual recommendations.

4.4] SM-FT-3000 - Durability Testing

The 3000 tool is fitted to the durability test jig and performs a continuous series of 25000 tightening operations. On completion of the test the tool was removed and used to tighten a 32mm Smart® Band Hybrid system in PA12 material.



The tool was then stripped down and the pertinent components checked for wear. The images below show minor wear on these constituent parts.

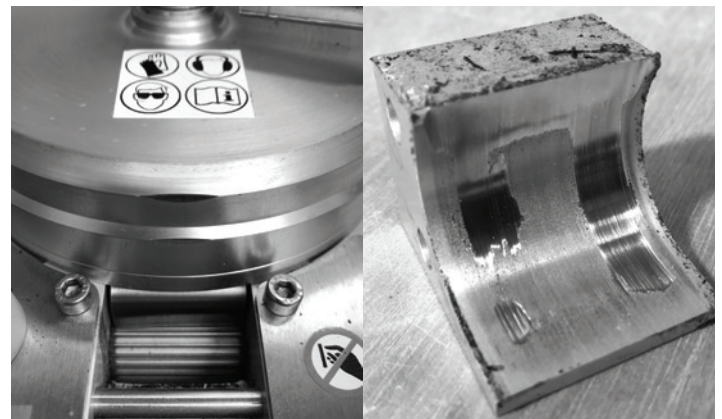

Note: It is recommended the tool should be recalibrated after extensive use. Refer to your HCL representative for advice.

5.1] System Tensile Tests – Introduction

System tensile testing of Smart® Tie and Smart® Band is carried out in controlled conditions. A bespoke fixture comprising of two half shells is mounted onto a tensile test machine. The Smart® Tie and Smart® Band Products are fitted to the fixture and are tested and monitored to ascertain the tensile strength of the system. Stress/strain graphs are plotted.

Test Fixture: 2x Steel half-shells
 Test pre-load: 200N
 Test Speed: 5mm/min (10mm/min Effective circumferential speed)
 Specimen Length: As per 'System Test Diameter and Circumference Table' below

The published data in this section are for specimens tested when new and "dry as moulded". As the polymers condition, these figures may vary.

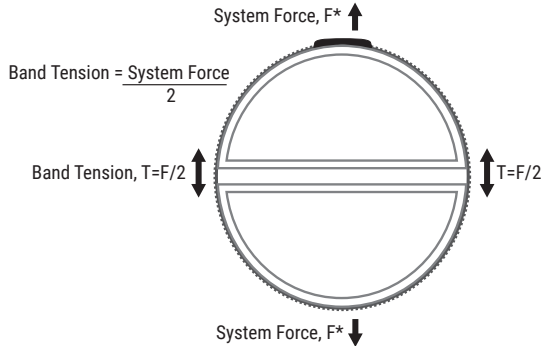

*F= System Force or Global Strap Tension

Note. The increased strain on the smaller diameters such as 200mm and 400mm is due to the flexing of the buckle as it bends around the profile.

5.1.1] System Test Diameter and Circumference Table

Test Diameter	Test Circumference
mm (inch)	mm (inch)
100 (3.9)	330 (13.0)
200 (7.9)	650 (25.6)
280 (11.0)	910 (35.8)
400 (15.7)	1300 (51.2)
600 (23.6)	1950 (76.8)
800 (31.5)	2600 (102.4)

5.2] Smart® Tie System Tensile Tests

5.2.1] Smart® Tie 20mm (3/8") System Tensile Tests

Line No	Band Size	Material	Test Diameter	System Yield Strength	Circumferential Yield Strain	
			mm	N (kgf) [lbf]	%	
1	20mm (3/8")	PA66	100	4976 (508) [1119]	18.0	SGS
2			200	4763 (486) [1071]	18.7	
3	20mm (3/8")	PA12	100	4048 (413) [910]	9.7	SGS
4			200	3848 (392) [865]	7.8	
5	20mm (3/8")	PK	100	5913 (603) [1329]	17.9	SGS
6			200	5594 (571) [1258]	15.1	
7	20mm (3/8")	PPS	100	5023 (512) [1129]	8.3	SGS
8			200	4774 (487) [1073]	10.2	

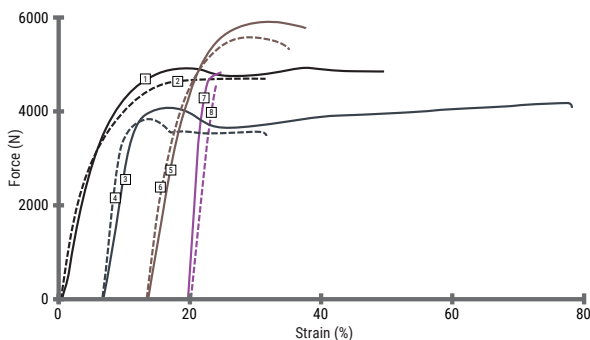

Note: Curves offset along x-axis in 5% intervals for clarity

5.2.2] Smart® Tie 32mm (1 1/4") System Tensile Tests

Line No	Band Size	Material	Test Diameter	System Yield Strength	Circumferential Yield Strain	
			mm	N (kgf) [lbf]	%	
1	32mm (1 1/4")	PA12	100	9306 (949) [2092]	9.1	SGS
2			200	9146 (933) [2056]	6.8	
3		PK	100	12536 (1279) [2818]	17.9	
4	200		12397 (1264) [2787]	15.3		

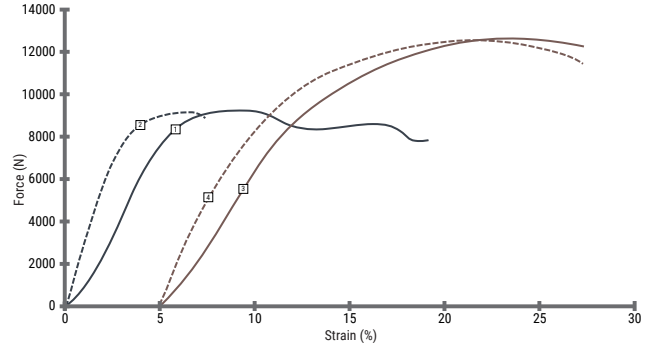

Note: Curves offset along x-axis in 5% intervals for clarity

5.3] Smart® Band System Tensile Tests – Standard Buckle

5.3.1] Smart® Band 7mm (1/4") Standard – PA66

Note. The figures quoted are for PA66 in the 'dry as moulded' condition. These figures will vary dependant on environmental conditioning.

Line No	Band Size	Material	Test Diameter	System Break Strength	Circumferential Break Strain
			mm	N (kgf) [lbf]	%
1	7mm (1/4")	PA66	100	1633 (167) [367]	65.9
2			200	1744 (178) [392]	59.0

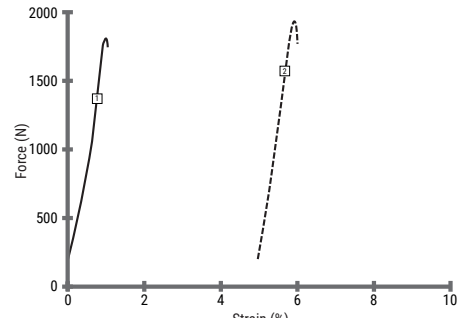

Note: Curves offset along x-axis in 5% intervals for clarity

5.3.2] Smart® Band 10mm (3/8") Standard System Test – PA66

Note. The figures quoted are for PA66 in the 'dry as moulded' condition. These figures will vary dependant on environmental conditioning.

Line No	Band Size	Material	Test Diameter	System Break Strength	Circumferential Break Strain
			mm	N (kgf) [lbf]	%
1	10mm (3/8")	PA66	100	2105 (215) [473]	3.3
2			200	2518 (257) [566]	2.1
3			280	2748 (253) [618]	1.8
4			400	3002 (306) [675]	1.7
5			600	2950 (301) [663]	1.7

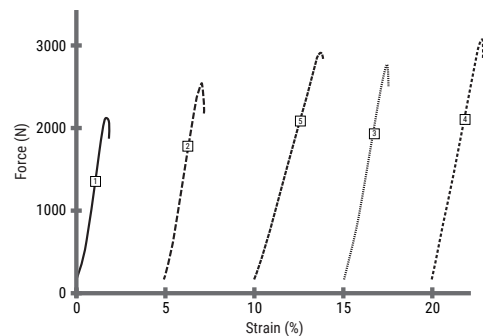

Note: Curves offset along x-axis in 5% intervals for clarity

5.3.3] Smart® Band 10mm (3/8") Standard System Test – PA12

Line No	Band Size	Buckle Material	Band Material	Test Diameter	System Break Strength	Circumferential Break Strain
				mm	N (kgf) [lbf]	%
1	10mm (3/8")	PA12	PA12	100	1337 (136) [301]	2.9
2				200	1551 (158) [349]	3.0
3				280	1449 (148) [326]	1.2
4				400	1312 (134) [295]	1.5
5				600	1609 (164) [362]	2.4
6				800	1760 (179) [396]	3.2

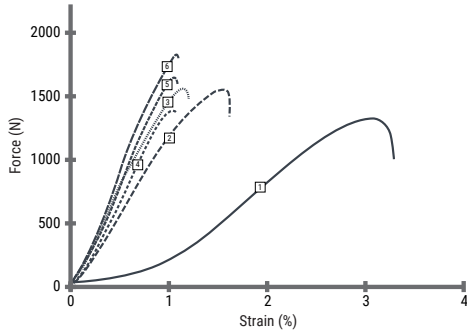

5.3.4] Smart® Band 19mm (3/4") Standard System Test – PA66

Note. The figures quoted are for PA66 in the 'dry as moulded' condition. These figures will vary dependant on environmental conditioning.

Line No	Band Size	Buckle Material	Band Material	Test Diameter	System Break Strength	Circumferential Break Strain
				mm	N (kgf) [lbf]	%
1	19mm (3/4")	PA66	PA66	100	3219 (328) [724]	3.6
2				200	3627 (370) [815]	1.7
3				280	3396 (346) [763]	1.2
4				400	3948 (403) [888]	1.2
5				600	4086 (417) [919]	0.9
6				800	3396 (346) [763]	0.8

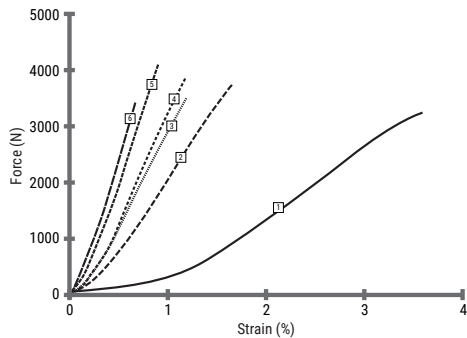

5.3.5] Smart® Band 19mm (3/4") Standard System Test – POM/PA66

Line No	Band Size	Buckle Material	Band Material	Test Diameter	System Break Strength	Circumferential Break Strain
				mm	N (kgf) [lbf]	%
1	19mm (3/4")	PA66	POM	100	3201 (327) [720]	4.0
2				200	3161 (322) [711]	2.2
3				280	3557 (363) [800]	1.7
4				400	3613 (369) [812]	1.7
5				600	3883 (396) [873]	1.5
6				800	3555 (363) [799]	1.5

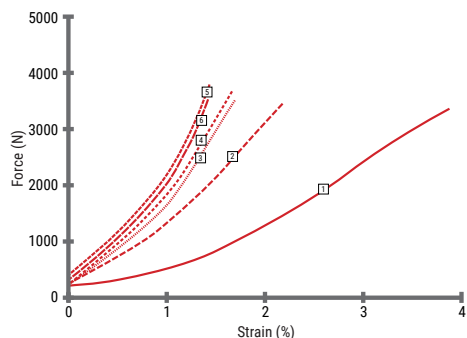

5.4] Smart® Band System Tensile Tests – Hybrid Buckle

5.4.1] Smart® Band 19mm (3/4") Hybrid System Test – PA66

Note. The figures quoted are for PA66 in the 'dry as moulded' condition. These figures will vary dependant on environmental conditioning.

Line No	Band Size	Material	Test Diameter	System Break Strength	Circumferential Break Strain
			mm	N (kgf) [lbf]	%
1	19mm (3/4")	PA66	200	11910 (1215) [2677]	3.7
2			280	13190 (1345) [2965]	2.7
3			400	11600 (1183) [2608]	2.2
4			600	12135 (1237) [2728]	2.0
5			800	11460 (1169) [2576]	1.7

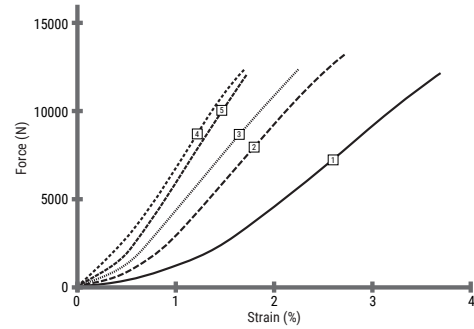

5.4.2] Smart® Band 19mm (3/4") Hybrid System Test – POM

Line No	Band Size	Material	Test Diameter	System Break Strength	Circumferential Break Strain
			mm	N (kgf) [lbf]	%
1	19mm (3/4")	POM	200	9490 (968) [2133]	4.0
2			280	9110 (929) [2048]	2.6
3			400	9030 (921) [2030]	2.4
4			600	9980 (1018) [2244]	2.3
5			800	11010 (1123) [2475]	2.1

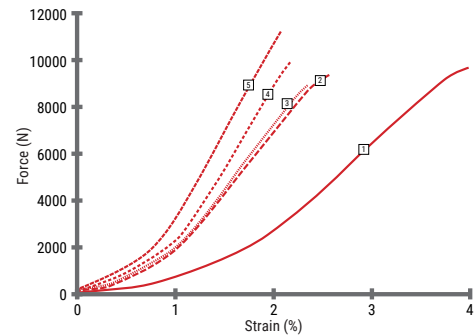

5.4.3] Smart® Band 19mm (3/4") Hybrid System Test – PA12GF

Line No	Band Size	Material	Test Diameter	System Break Strength	Circumferential Break Strain
			mm	N (kgf) [lbf]	%
1	19mm (3/4")	PA12GF	200	12530 (1278) [2817]	2.8
2			280	12990 (1325) [2920]	2.0
3			400	12470 (1272) [2803]	1.7
4			600	12950 (1321) [2911]	1.5
5			800	12760 (1302) [2868]	1.5

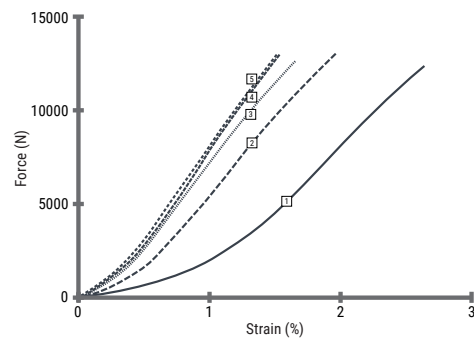

5.4.4] Smart® Band 32mm (1¼") Hybrid System Test – POM

Line No	Band Size	Material	Test Diameter	System Break Strength	Circumferential Break Strain
			mm	N (kgf) [lbf]	%
1	32mm (1¼")	POM	200	15180 (1548) [3412]	6.5
2			280	16500 (1683) [3709]	4.2
3			400	16090 (1641) [3617]	3.1
4			600	17200 (1754) [3867]	2.5
5			800	17380 (1773) [3907]	2.4

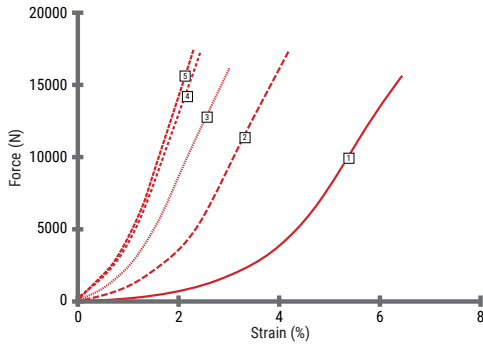

5.4.5] Smart® Band 32mm (1¼") Hybrid System Test – PA12GF

Line No	Band Size	Material	Test Diameter	System Break Strength	Circumferential Break Strain
			mm	N (kgf) [lbf]	%
1	32mm (1¼")	PA12GF	200	20860 (2128) [4689]	5.9
2			280	22580 (2303) [5076]	3.2
3			400	23000 (2346) [5170]	2.3
4			600	22980 (2344) [5166]	1.7
5			800	22650 (2310) [5092]	1.7

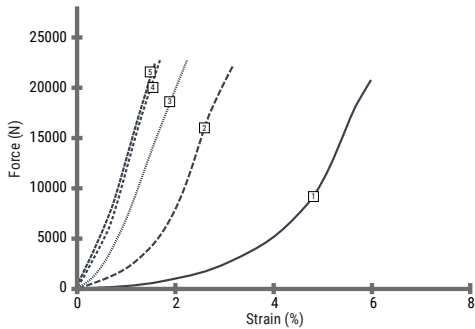

5.5] Smart® Band Compact System Tensile Tests

5.5.1] Smart® Band Compact 19mm (¾") System Tensile Tests – PA12GF

Line No	Band Size	Material	Test Diameter	System Break Strength	Circumferential Break Strain
			mm	N (kgf) [lbf]	%
1	19mm (¾")	PA12GF	100	15384 (1569) [3458]	3.9
2			200	15488 (1579) [3482]	5.3
3			600	14218(1450) [3196]	1.7

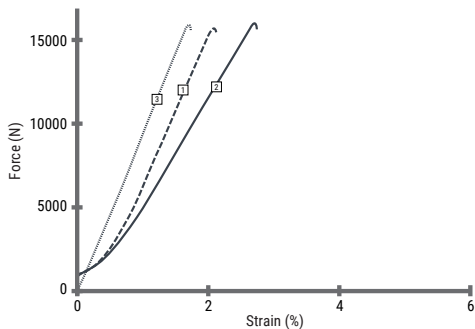

5.5.2] Smart® Band Compact 19mm (¾") System Tensile Tests – PPS

Line No	Band Size	Material	Test Diameter	System Break Strength	Circumferential Break Strain
			mm	N (kgf) [lbf]	%
1	19mm (¾")	PPS	600	11927 (1216) [2681]	1.7

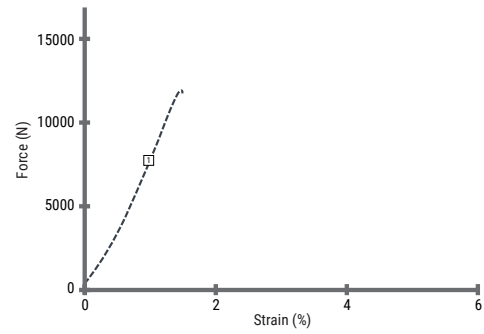

5.5.3] Smart® Band Compact 32mm (1¼") System Tensile Tests – PA12GF

Line No	Band Size	Material	Test Diameter	System Break Strength	Circumferential Break Strain
			mm	N (kgf) [lbf]	%
1	32mm (1¼")	PA12GF	280	26540 (2706) [5966]	2.5
2			600	26372 (2689) [5929]	1.8

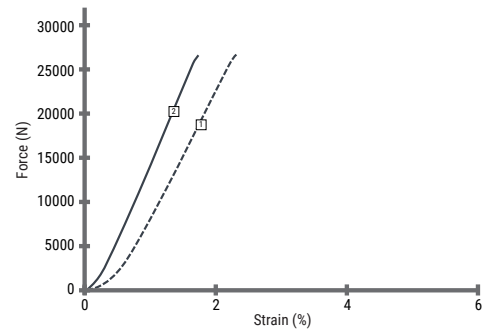

5.5.4] Smart® Band Compact 32mm (1¼") System Tensile Tests – PPS

Line No	Band Size	Material	Test Diameter	System Break Strength	Circumferential Break Strain
			mm	N (kgf) [lbf]	%
1	32mm (1¼")	PPS	200	20287 (2069) [4561]	1.2
2			400	21696 (2212) [4877]	2.3
3			600	22328 (2277) [5020]	2.0

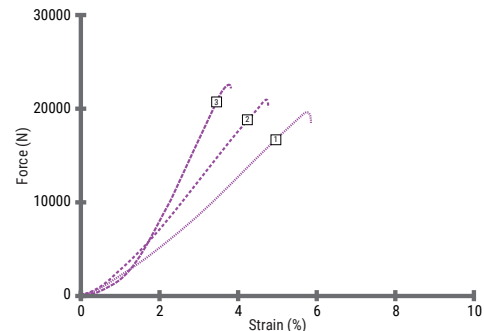

6] Creep and Stress Relaxation

The phenomenon known as creep describes how materials strain (stretch/compress) when subjected to a constant stress (tensile/compressive force). Stress Relaxation, which views the same phenomena from a different stand point, describes how materials relieve stress when subjected to a constant strain. In simple terms:

Creep: The test specimen is held at a constant force and the deformation (increase/decrease in length) is measured over time.

Stress Relaxation: The test specimen is held in a constant position and the change in force (increase/decrease) is measured over time.

Smart® Band is made from a combination of engineering polymers, which possess strong creep resistant characteristics, in combination with glass fibre yarn to reduce the effects of creep to a minimum.

6.1] Stress Relaxation

This section concentrates on Stress Relaxation, which is generally more relevant in strapping applications. All tests were carried out at 20°C.

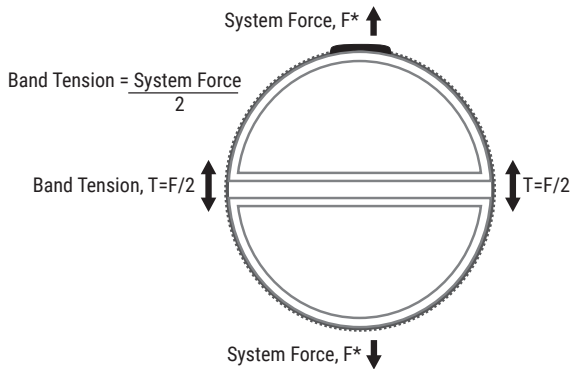

Note. All tests carried out using half shells mounted on a load cell

6.1.1] Smart® Tie 20mm (3/4") System in Air

Note. The Smart® Tie 20mm is fitted and tightened to a 100mm diameter half shell which is mounted on a tensile test machine. The tightening tension is controlled by using the SM-FT-1000 tool at the specified torque setting. The tensile machine cross beam is held at a constant position for 10 days and the tension force is recorded over this time. The results are extrapolated onto a log graph to determine the stress relaxation over the lifetime of the product.

Line No	Product	Band Size	Band & Buckle Material	Starting System Force	Tension after 1 Year Approx	Tension after 5 Years Approx	Tension after 25 Years Approx
				N	N	N	N
1	Smart® Tie	20mm (3/4")	PA66	2,000	700	600	450
2	Smart® Tie	20mm (3/4")	PPS	1,000	750	725	700

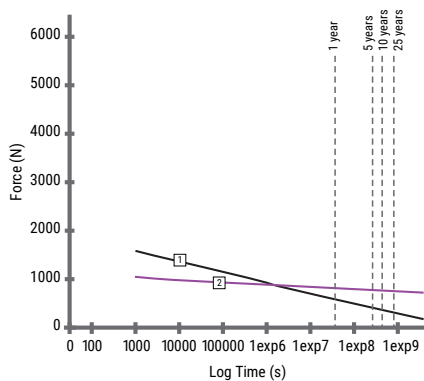

6.1.2] Smart® Tie 32mm (1 1/4") System in Air

Note. The Smart® Tie 32mm is fitted and tightened to a 200mm diameter half shell which is mounted on a tensile test machine. The tightening tension is controlled by using the SM-FT-1000 tool at the specified torque setting. The tensile machine cross beam is held at a constant position for 10 days and the tension force is recorded over this time. The results are extrapolated onto a log graph to determine the stress relaxation over the lifetime of the product.

Product	Band Size	Band & Buckle Material	Starting System Force	Tension after 1 Year Approx	Tension after 5 Years Approx	Tension after 25 Years Approx
			N	N	N	N
Smart® Tie	32mm (1 1/4")	PK	4,000	1900	1600	1400

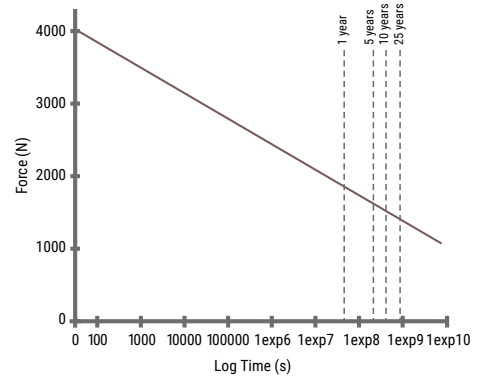

6.1.3] Smart® Band 19mm (3/4") Hybrid System in Air

Note. The Smart® Band 19mm hybrid system is fitted and tightened to a 600mm diameter half shell which is mounted on a tensile test machine. The tightening tension is controlled by using the SM-FT-1000 tool at the specified torque setting. The tensile machine cross beam is held at a constant position for 10 days and the tension force is recorded over this time. The results are extrapolated onto a log graph to determine the stress relaxation over the lifetime of the product.

Line No	Product	Band Size	Band & Buckle Material	Starting System Force	Tension after 1 Year Approx	Tension after 5 Years Approx	Tension after 25 Years Approx
				N	N	N	N
1	Smart® Band	19mm (3/4")	PA66	5,000	4000	3900	3800
2			POM	5,000	3100	2800	2600
3			PA12GF	5,000	3600	3400	3100

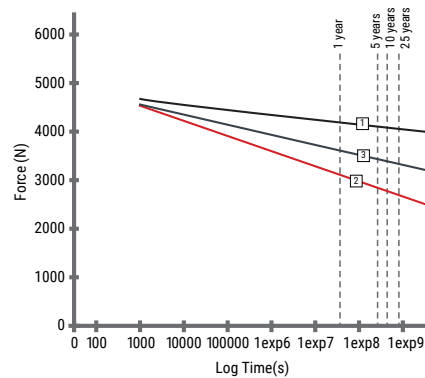

6.1.4] Smart® Band 32mm (1 1/4") Hybrid System in Air

Note. The Smart® Band 32mm hybrid system is fitted and tightened to a 600mm diameter half shell which is mounted on a tensile test machine. The tightening tension is controlled by using the SM-FT-1000 tool at the specified torque setting. The tensile machine cross beam is held at a constant position for 10 days and the tension force is recorded over this time. The results are extrapolated onto a log graph to determine the stress relaxation over the lifetime of the product.

Line No	Product	Band Size	Band & Buckle Material	Starting System Force	Tension after 1 Year Approx	Tension after 5 Years Approx	Tension after 25 Years Approx
				N	N	N	N
1	Smart® Band	32mm (1 1/4")	POM	10,000	6000	5500	4800
2	Smart® Band	32mm (1 1/4")	PA12GF	10,000	7300	7100	6800

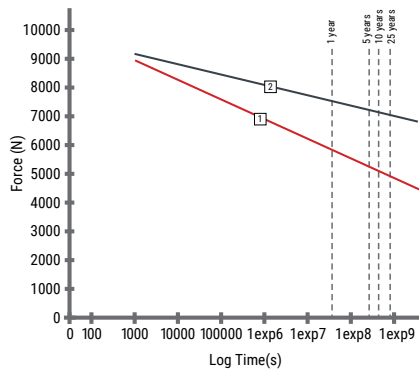

6.1.5] Smart® Band & Smart® Tie Systems in Water

The Smart® Band products are set up on dia 600 half shell unit in a stress relaxation test tank and on dia 400 half shells in a multiple set-up in a multi-test stress relaxation tank. Smart® Tie product is set up on dia 200 half shells within the same test tank. The half shells are fitted with individual load cells which are subsequently linked to data loggers for continuous recording. The half shells are submersed within a tank of deionized water which is maintained at a constant temperature of 20°C (68°F).

Multi-Test Stress Relaxation Tank With Dia 200mm & 400mm Half Shell Tank

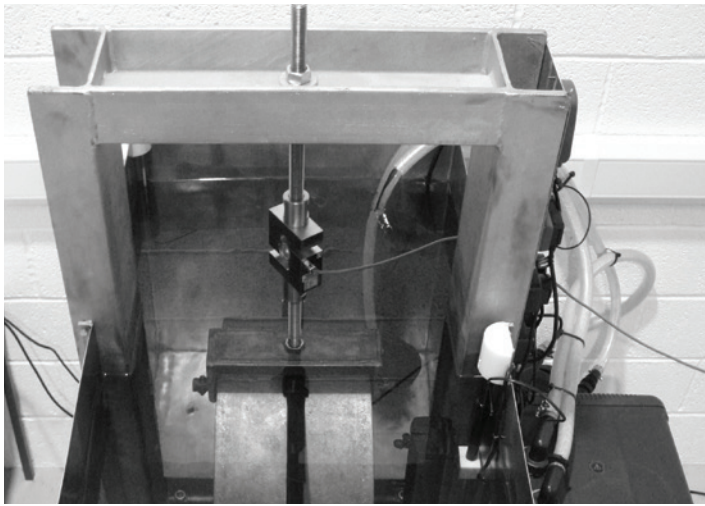

Single Unit Stress Relaxation Tank With dia 600mm Half Shell



6.1.5.1] 32mm Smart® Band Hybrid PA12GF – Graph – Log Time

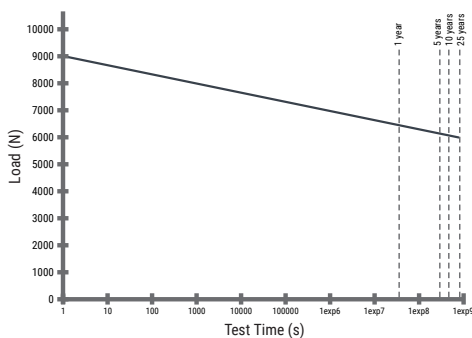

6.1.5.2] 32mm Smart® Band Compact PA12GF – Graph – Log Time

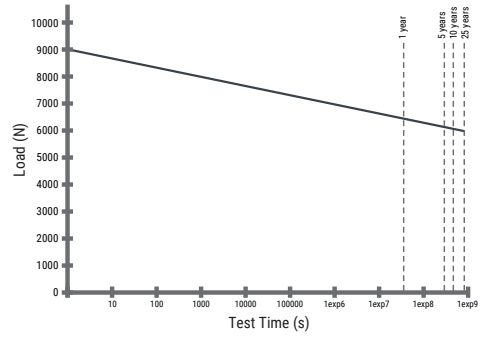

6.1.5.3] 32mm Smart® Tie PA12 – Graph – Log Time

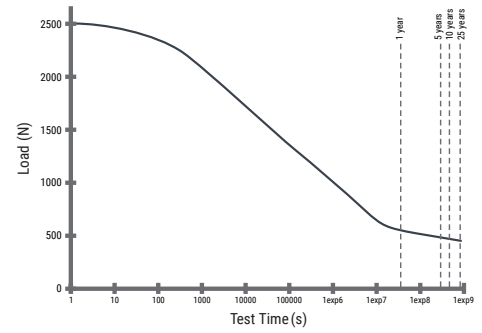

6.1.5.4] 32mm Smart® Tie PK – Graph – Log Time

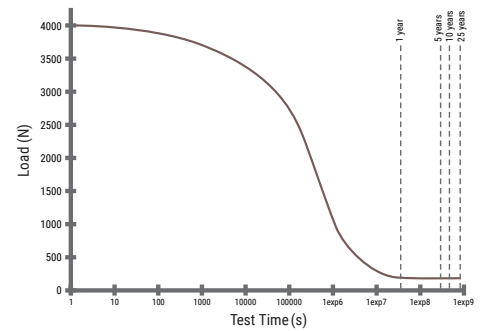

6.1.5.5] 32mm Smart® Tie PPS – Graph – Log Time

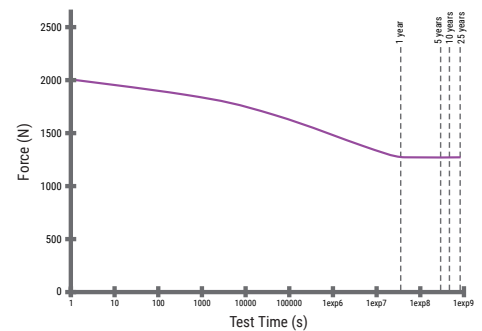

It should be noted that moisture uptake in the PA12 material accelerates the rate of stress relaxation during the first 6 months (during this period saturation is reached).

7] Axial Retention

Axial retention is an important consideration when clamping cables to downhole pipes. The clamping retention of the cable must be large enough to cope with two aspects of the installation:

1. The weight of the cable
2. The expected resistance when snags and joints etc. are encountered.

Open well situations need very careful consideration as the forces encountered from snags may be much higher than a cased well installation.

7.1] Banding Axial Retention

The following jig setup on a Tensile Testing machine was used to measure the axial retention for Smart® Tie and Smart® Band products. The tests include a comparison with steel strap.

Test pre-load: 20N

Test Speed: 10mm/min

Steel Tube Surface Finish: Sand-blasted finish. Grit size FEPA F46 (370µm mean diameter)

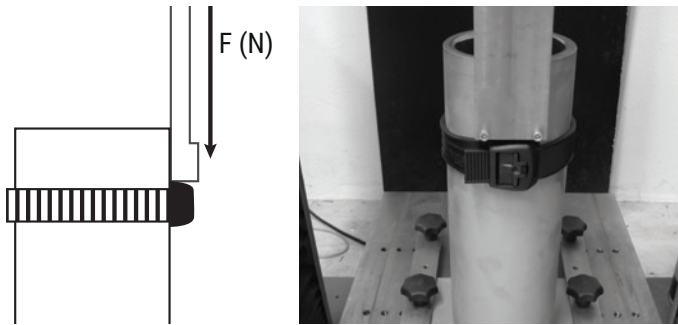

7.1.1] Smart® Tie 20mm (¾") Axial Retention

Line No	Banding		Steel Tube Ø mm (inch)	Description	Axial Retention	
	Product	Material			Max Force (N)	Total Movement (mm)
1		PA66	120.5 (4.74)	Axial loading applied to Smart® Tie head	3957	50.1
2	Smart® Tie 20mm (¾")	PA12			3734	106.3
3		PK			4300	61.3
4		PPS			2241	37.1
5	Metal Banding 19mm (¾")	Stainless Steel			3975	36.6

NB. Axial Retention varies with the band tension and surface finish of the application.

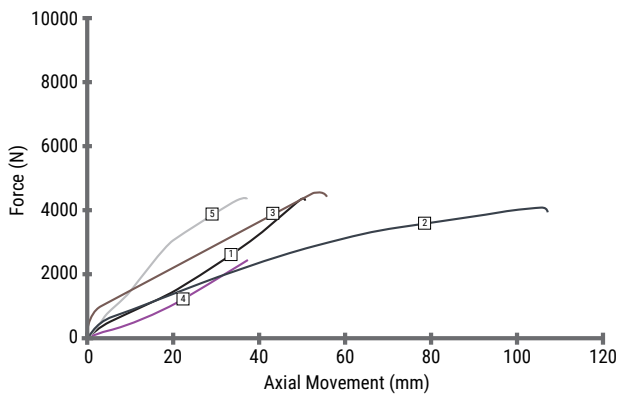

7.1.2] Smart® Tie 32mm (1¼") Axial Retention

Line No	Banding		Steel Tube Ø mm (inch)	Description	Axial Retention	
	Product	Material			Max Force (N)	Total Movement (mm)
1	Smart® Tie 32mm (1¼")	PA12	120.5 (4.74)	Axial loading applied to Smart® Tie head	6463	87.7
2		PK			9520	79.1

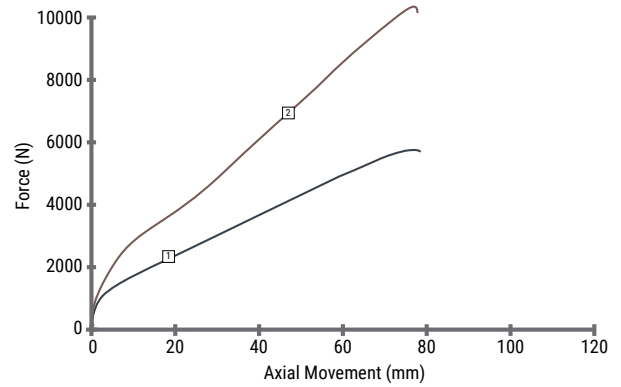

7.1.3] Smart® Band 19mm (¾") Axial Retention

Line No	Banding		Steel Tube Ø mm (inch)	Description	Axial Retention	
	Product	Material			Max Force (N)	Total Movement (mm)
1	Smart® Band 19mm (¾")	PA66	200 (7.87)	Axial loading applied to Smart® Band head	2684	34.0
2		PA12GF			2756	24.5

NB. Axial Retention varies with the band tension and surface finish of the application.

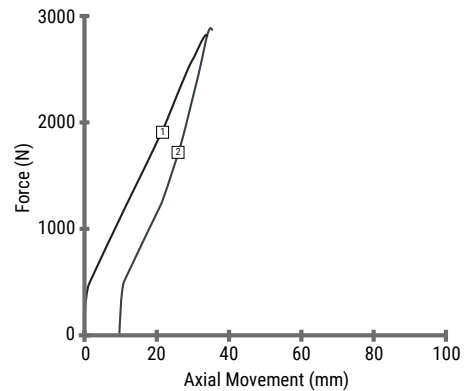

Note: Curves offset along x-axis in 10mm intervals for clarity.

7.2] Banding and Smart® Protector Assembly Axial Retention

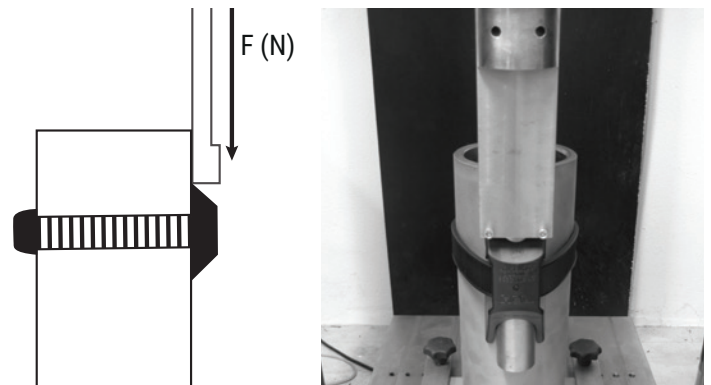

7.2.1] SP-100 with Smart® Tie 20mm (¾")

Line No	Product	Material	Steel Tube Ø mm (inch)	Axial Retention	
				Max Force (N)	Total Movement (mm)
1	Smart® Tie 20mm (¾")	PA66	120.5 (4.74)	4901	71.0
2		PA12		3310	84.2

Note. Axial Retention varies with the band tension and surface finish of the application.

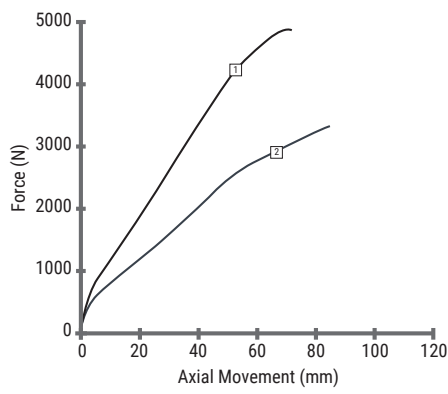

7.2.2] SP-200 with Smart® Tie 20mm (¾") and Smart® Tie 32mm (1¼")

Line No	Smart® Tie	Material	Steel Tube Ø	Axial Retention	
	Size		mm (inch)	Max Force (N)	Total Movement (mm)
1	20mm (¾")	PA66	120.5 (4.74)	3882	54.6
2	20mm (¾")	PA12		3932	119.6
3	32mm (1¼")	PPS		2274	31.5
4	32mm (1¼")	PA12		6320	100

Note. Axial Retention varies with the band tension and surface finish of the application.

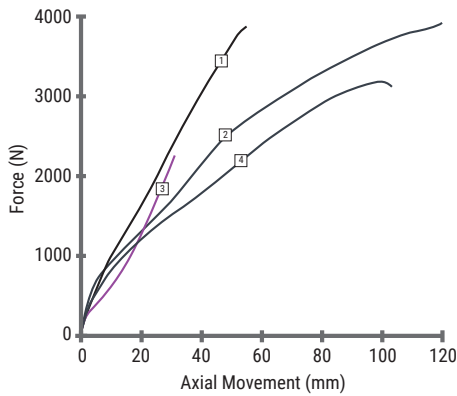

7.2.3] SP-300 with Smart® Tie 20mm (¾") and Smart® Tie 32mm (1¼")

Line No	Smart® Tie	Material	Steel Tube Ø	Axial Retention	
	Size		mm (inch)	Max Force (N)	Total Movement (mm)
1	20mm (¾")	PA66	120.5 (4.74)	4472	67.6
2	20mm (¾")	PA12		3469	106
3	32mm (1¼")	PPS		2538	4.3
4	32mm (1¼")	PA12		6120	104

Note. Axial Retention varies with the band tension and surface finish of the application.

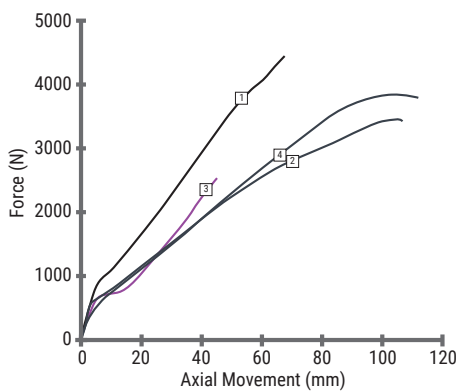

7.2.4] SP-400-3820 with Smart® Tie 20mm (¾") and Smart® Tie 32mm (1¼")

Line No	Smart® Tie	Material	Steel Tube Ø	Axial Retention	
	Size		mm (inch)	Max Force (N)	Total Movement (mm)
1	20mm (¾")	PA66	120.5 (4.74)	1620	35.7
2	20mm (¾")	PA12		3047	99
3	32mm (1¼")	PPS		2606	61.2
4	32mm (1¼")	PA12		5119	78.3

Note. Axial Retention varies with the band tension and surface finish of the application.

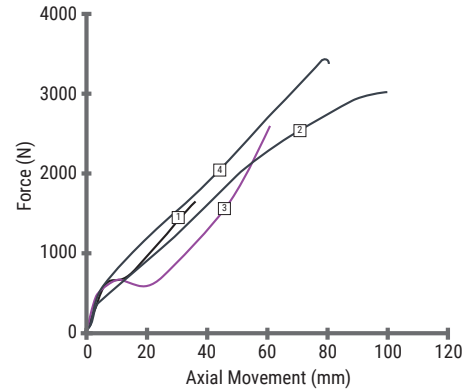

7.2.5] SP-400-5228 with Smart® Tie 20mm (¾") and Smart® Tie 32mm (1¼")

Line No	Smart® Tie	Material	Steel Tube Ø	Axial Retention	
	Size		mm (inch)	Max Force (N)	Total Movement (mm)
1	20mm (¾")	PA66	120.5 (4.74)	2719	40.4
2	20mm (¾")	PA12		3995	109
3	32mm (1¼")	PPS		2551	50.2
4	32mm (1¼")	PA12		6369	90.1

Note. Axial Retention varies with the band tension and surface finish of the application.

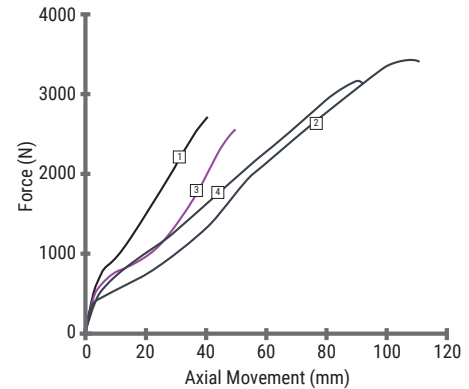

7.2.6] SP-500-1721 with Smart® Tie 20mm (¾") and Smart® Tie 32mm (1¼")

Line No	Smart® Tie	Material	Steel Tube Ø	Axial Retention	
	Size		mm (inch)	Max Force (N)	Total Movement (mm)
1	20mm (¾")	PA66	120.5 (4.74)	4645	71.9
2	20mm (¾")	PA12		3453	104
4	32mm (1¼")	PPS		TBC	TBC
5	32mm (1¼")	PA12		4975	87

Note. Axial Retention varies with the band tension and surface finish of the application.

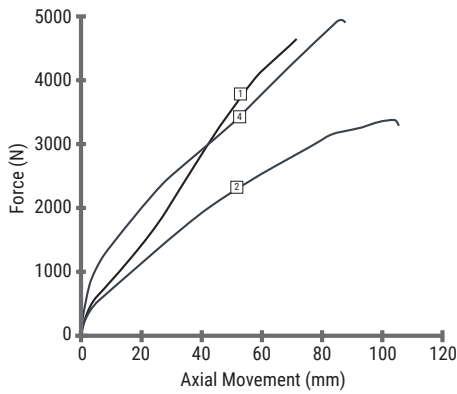

7.2.7] SP-500-3338 with Smart® Tie 32mm (1 1/4")

Line No	Smart® Tie	Material	Steel Tube Ø	Axial Retention	
	Size		mm (inch)	Max Force (N)	Total Movement (mm)
1	32mm (1 1/4")	PA12	120.5 (4.74)	6471	100

Note. Axial Retention varies with the band tension and surface finish of the application.

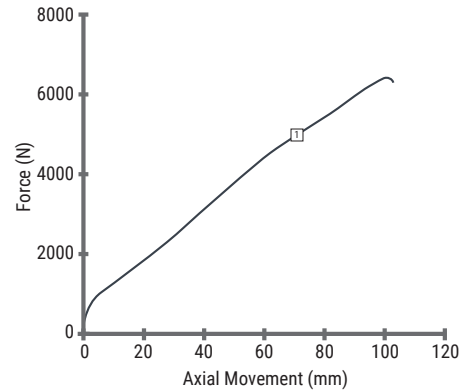

8] Roller Testing

Roller testing is carried out on bespoke test equipment that replicates the action of the rollers (Stingers) used in "S" lay pipe deployment.

A test pipe fitted with Smart® products is passed under rollers that have been set to apply a controlled force to the pipe and associated Smart® products.

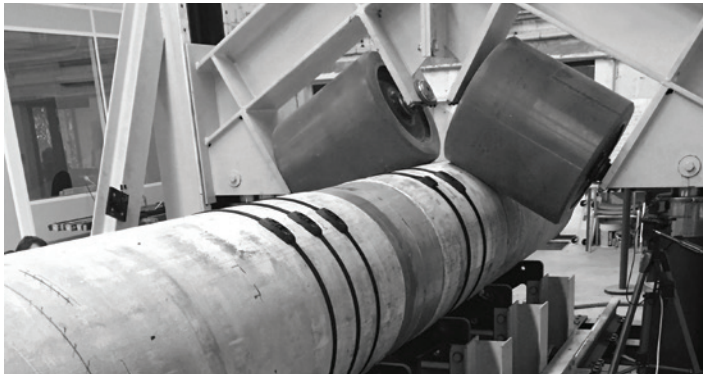

Test Pipe – Ø620mm including a 3LPP coating.

Rollers – Ø540mm including a PP coating (90 Shore A Hardness) of 61mm thick.

A vertical force of up to 100 Tonnes is applied through the rollers.

The pipe is cycled forward and back under the rollers.

Product	Loading	No of Cycles	Pass/Fail
	KN		
19mm (3/4") Smart® Band	1000	70	Pass
32mm (1 1/4") Smart® Band	1000	70	Pass
19mm (3/4") Smart® Band Hybrid Buckle	1000	12	Pass
19mm (3/4") Smart® Band Hybrid Buckle	300	50	Pass

Note. Wherever possible it is best practice to locate the buckle of the Smart Band system away from the rollers.

Figures above are based on tests carried out on product manufactured from PA12GF Material.

9] Impact Strength

Whether it is a downhole, subsea or a topside application there is a good chance that Smart® products will encounter considerable impact at times. Smart® Products are designed with impact resistance in mind.

The following data is derived from various tests involving dropping a known weight from a known height.

The standard energy equation – Energy (Joules) = mgh is applied where:

$$m = \text{Mass (Kg)} \quad g = \text{Gravity } 9.81 \text{ (m/s}^2\text{)} \quad h = \text{Height (m)}$$

9.1] Smart® Band Impact Strength

The weight is adjusted accordingly to set the correct impact energy but the bottom impact area of the weight is always 100mm (4 inches) in diameter.

Size/Component	Material	Maximum Impact Energy Without Loss of Integrity or Tension J
19mm (3/4") Band	PA12GF	5000+*
19mm (3/4") Hybrid Buckle		5000+*
32mm (1 1/4") Band	PA12GF	5000+*
32mm (1 1/4") Hybrid Buckle		5000+*

*The material maintained integrity after impacts of maximum possible energy from apparatus used 176Kg x 9.81 m/s² x 2.91m = 5000 Joules (2 sig fig).



9.2] Smart® Protector Impact Strength

The rig-floor durability of the SP-300 in PA66 material was testing using an impact rig setup as shown below. The maximum height and weight which the moulding survives indicated the sustainable impact energy level.

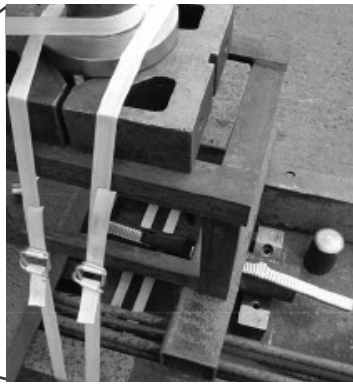

The impact testing was conducted using an impactor of a variable weight, dropping it from various heights. Runs progressively reduce both factors until the Smart® Protector survives the impact. Note that the test is conducted using purely the protector alone (to simulate rig-floor use) and therefore does not contain an insert such as an ESP cable that would give it more impact strength if in downhole use.

	Drop Height (mm)	Weight (kg)	Impact Energy (J)	Result
Test 1	4470	2.34	103	Failure - fractured
Test 2	3080	2.66	80.3	Slight bruising
Test 3	4080	2.66	106	Slight bruising

10] Half Shell Minimum Bending Radius

Due to a dynamic environment, umbilicals and risers are often subjected to aggressive bending.

The test Minimum Bend Radius (MBR) is usually a few metres but to ensure absolute compliance and to give a good safety factor, they are often subjected to a much tighter radius.

Smart® Band has been well proven to stand an MBR of less than one metre for this type of application.

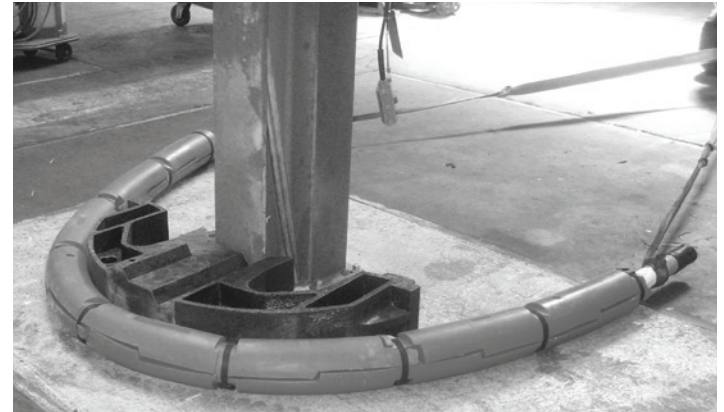
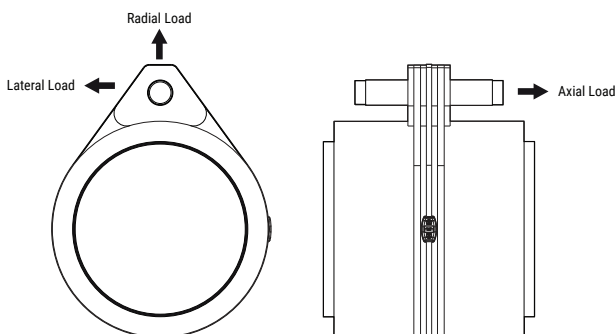
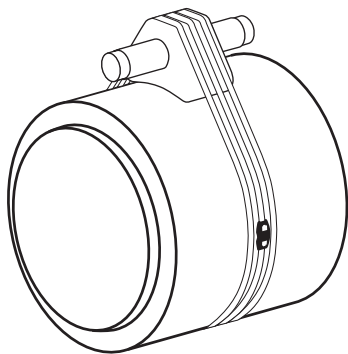

Photo courtesy of Lankhorst/Mouldings BV
 19mm/¾" Smart® Band PA11GF clamped on a UraGUARD Half Shell Test
 Minimum Bend Radius: 0.68m
 Water depths: 600m to 1200m
 Final Installation Location: West Coast of Angola

11] Piggyback Pipe Lay

11.1] Smart® Band Piggyback Performance

The following tests were carried out to obtain the performance of Smart® Band 32mm (1¼") PA12GF Hybrid system when used in a Piggyback block Pipe Lay application. During the tests a Piggyback block arrangement was loaded with radial, axial and lateral forces. For axial and lateral loading, the movement of the saddle was measured relative to the carrier pipe; for radial loading, the system break strength was recorded.



11.1.1] Tool Tightening Forces

Pneumatic Tightening Tool Type	Air Pressure	System Retention
	MPa (Bar) [psi]	N (Kg) [lbs]
32mm (1¼") Steel Strap – Signode PRHR-114 ¹	0.6 (6.0) [87]	6200 (632) [1390]
32mm (1¼") Smart® Band PA12GF – SM-FT-3000-32	0.55 (5.5) [80]	9000 (918) [2023]
32mm (1¼") Smart® Band PA66* – SM-FT-3000-32	0.55 (5.5) [80]	13500 (1377) [3055]

¹ For comparison purposes only

*Smart® Band PA66 is suitable for initial installation loadings but after a number of months subsea it should be expected that the retention will drop off due to the hygroscopic nature of the material.

11.1.2] Test Results

Loading Direction	Saddle Type	Pipe Diameters mm (inch)	32mm (1¼") Smart® Band PA66x2 PA12GFx1 – 3 Straps	
			Loading (kN) At Point of Movement	Loading (kN) After 50mm Movement
Axial	Rubber	600 + 120 (24 + 5)	11.5	22.6
Lateral	Rubber	600 + 120 (24 + 5)	10.0	16.0
Radial	Rubber	600 + 120 (24 + 5)	50+ ²	50+ ²

² System survived maximum force of 50kN+ to the limit that the tensile test machine could achieve.

Note: It should be noted that these tests were only carried out in the particular arrangements above and that clients should carry out their own tests, as Piggyback arrangements vary from application to application.

For further test information please contact HCL.

12] Hydrostatic Compression

In deep water applications hydrostatic compression is a factor that needs to be taken into account when objects are clamped. In applications such as strake, cable/riser protection, insulation and buoyancy the high pressures in deep water have a crushing effect on the material causing the overall diameter to reduce. The strapping solution needs to be able to take up the reduction in diameter to give continual retention to the object being clamped.

Smart® Band is better suited to cope with Hydrostatic Compression when compared with traditional steel strapping solutions because of its lower strap stiffness. Strain is higher under tension than steel and so as compression takes place, band tension reduces less than steel which will lose tension quickly as compression takes place.

12.1] Typical Hydrostatic Compression Test Simulation

The following graphs give an example using 32mm Smart® Band PA11GF around a 353mm diameter half shell arrangement.

The two steel half shells have a polyethylene surface to simulate a polyethylene strake. The Smart® Band is tightened using a calibrated SM-FT-1000 tool. Over a period of 24 hours the diameter is reduced by 2.7mm to simulate the strake being lowered and experiencing hydrostatic compression. The system is then left for 10 days to determine any creep that might take place. On the graph, log time has been extrapolated to give the estimated retention over many years.

Note: The polyethylene surface is smoother than the steel surface and so friction does not have as much effect. The initial tension is therefore higher at around 10%.

12.1.1] Retention Force (N) against Log Time (s)

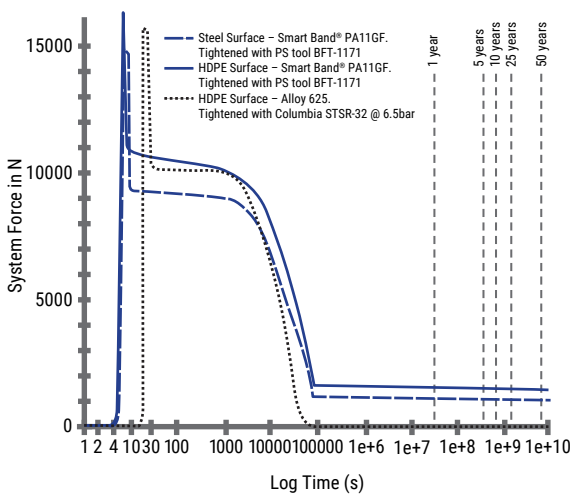

12.1.2] Retention Force (N) against Time (s)

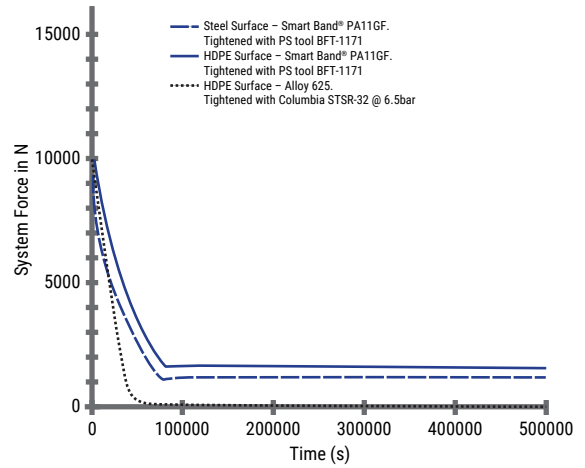

Note: Customer tests can be performed for individual applications

13] Abrasion

13.1] Polymer Abrasion Comparison

Abrasion resistance is described as the susceptibility to wear caused by the contact of dissimilar surfaces.

Smart® Band has been widely used in offshore applications where abrasion is a factor.

The banding has been proven to withstand abrasive conditions and shock from foreign debris that are often evident near the shore line.

Description	Standard	PA66	POM	PA12	PA12GF	PK	PPS
Dry As Moulded							

Mechanical Properties

Abrasion Resistance	The figures shown are relative to Nylon (PA12). The figure 2.8 indicates that the material is 2.8 times more susceptible to wear than Nylon (PA12).	NFT 46-102	2.8	TBC	1	2	TBC	TBC
---------------------	---	------------	-----	-----	---	---	-----	-----

13.2] Downhole Smart® Protector Abrasion

The following test rig was used to test the SP-300 in PA66 for abrasion.

The rig is designed to simulate abrasion experienced while running into a cased oilwell with 40ft joint spacings. The joint along the internal face of the casing string is ideally flush, but in the worst case could be ½" wide.

The two images directly below show the hydraulic ram which applies the required side load to simulate well doglegs.

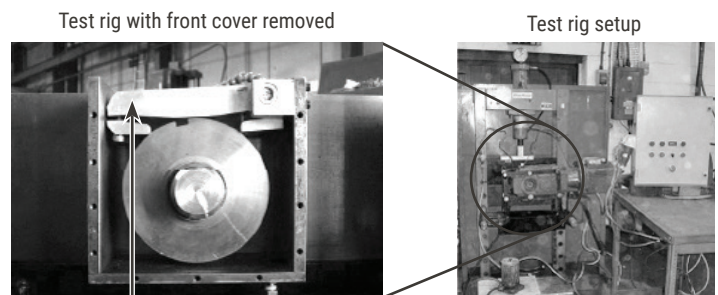

Hydraulic ram applies 2.5 tons sideload against wheel.

The abrasion test was conducted using the worst casing joint gap on the abrading wheel with a constant extreme load running against the moulded parts, as shown in the three images directly below. The wheel was run to simulate a determined number of casing feet and joints. Boiling water was also continuously flooded onto the abrading zone during the test.

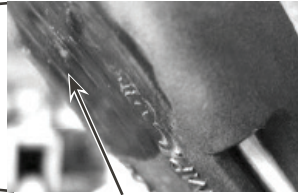
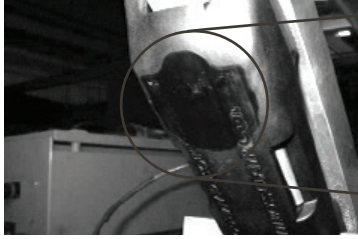
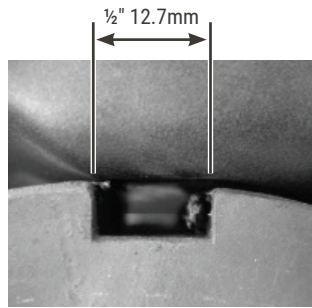

Extent of abrasion for Test 1

Note: Water temperature was 100 °C. Linear abrasion speed was 60 ft/min (0.3m/sec)

The results are shown in the table below:

	Casing Distance ft	No of Joints	Side Loading ton	Description	Result
Test 1	38,400	960	2.5	SP-300, PA6.6	Minor surface wear
Test 2	6,600	165	2.5	SP-300, PA6.6 soaked in diesel	Minor surface wear

13.3] Concrete Surfaces

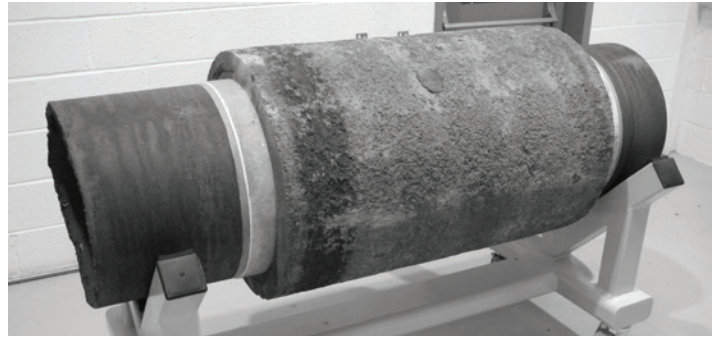

Tests have been carried out fitting various Smart® Band product to concrete coated pipe. This was to determine if the abrasive surface of the concrete pipe had an adverse effect to the product during fitting.

The fitting tests were carried out using the SM-FT-1000, SM-FT-2000 & SM-FT-3000 tool. Maximum tensions were applied for each tool type.

Every product fitted to the concrete pipe as expected. The Smart® Band systems were then removed from the concrete pipe and visually inspected. No problematic abrasion had occurred during the fitting process.

14] Marine Growth

Smart® Band has been well proven in applications such as pile wrapping where marine growth is a common factor. The integrity of the buckle and band is not compromised by marine growth and the banding remains permanently tight in this aggressive environment.



The photo on the left shows Smart® Band 10mm (3/8") in Nylon 6.6. fitted to a pier pile jacket on the southern coast of the United Kingdom. After 10 years. Smart® Band is still performing well and is unaffected by the barnacle growth.



The photo on the left shows Smart® Band 25mm Low Profile Buckle* system fitted to a pile jacket in Western Australia 2009. The second photo on the right shows the same pile after 5 years. Smart® Band is still tight and holding firm in spite of the significant barnacle growth and wave action over this time.

*Please note that the 25mm Low profile buckle system has now been superseded by the superior Smart® Band hybrid buckle system in 19mm and 32mm widths.

15] Temperature Resistance and Flammability

The following information gives maximum and minimum temperature recommendations for the Engineering polymers used in the production of the Smart® product range. It should be noted that as temperatures increase, mechanical properties generally reduce.

It is important that full well tests are carried out to ensure suitability for applications especially where raised temperatures are an issue. There may also be other chemicals in the vicinity that can adversely affect the performance of the polymers especially at higher temperatures and should be considered when specifying Smart® products. In aggressive high temperature environments it is recommended to select either flexible PPS or PEEK as the base polymer.

The data on flammability gives UL94 ratings for the different polymers. With the introduction of flexible PPS and PEEK the Smart® product range now boasts VO rated flammability.

Description	Standard	Units	PA66	POM	PA12	PA12GF	PK	PPS	PEEK
			Dry As Moulded		Dry As Moulded	Dry As Moulded			
Temperature Recommendations									
Working Temperature									
Minimum °C	General guidelines on permissible application temperatures	°C	-30	-30	-40	-40	-40	-40	-60
		(°F)	(-22)	(-22)	(-40)	(-40)	(-40)	(-40)	(-76)
Maximum Continuous* °C		°C	125	95	100	110	125	175	250
	(°F)	(257)	(203)	(212)	(230)	(257)	(347)	(482)	
Occasional Peaks °C		°C	160	130	130	135	160	200	280
	(°F)	(320)	(266)	(266)	(266)	(275)	(320)	(392)	(536)

Thermal Properties

Melting Point	The temperature at which the Polymer melts, i.e. turns from a solid to a liquid	ISO 11357	°C	260	165	178	178	220	280	343
			(°F)	(500)	(329)	(352)	(352)	(428)	(536)	(649)
Heat Deflection Temperature										
1.82 MPa	A measure of short-term heat resistance. A test specimen is loaded in a 3-point bending configuration, then heated until a specified deflection is reached	ISO 75	°C	70	95	45	160	85	103	160
		(°F)	(158)	(203)	(113)	(320)	(185)	(217)	(320)	
0.45 MPa		ISO 75	°C	200	156	115				/
	(°F)	(392)	(313)	(239)						
Vicat Softening Temperature										
50N	The temperature at which a flat-ended needle penetrates a test specimen to a depth of 1mm under a specified load	ISO 306	°C	236		154	170		225	/
		(°F)	(457)		(309)	(338)	(437)	/		
10N		ISO 306	°C	255	160	166		270		/
	(°F)	(491)	(320)	(331)		(518)				
Coefficient of Linear Thermal Expansion										
2mm - Parallel, 23°C - 55°C	A measure of the change in size of an object as its temperature changes	ISO 11359	10 ⁻⁵ mm/mm/°C	1.1	10	1.2	0.2		8	4.95
2mm - Normal, 23°C - 55°C		ISO 11359	10 ⁻⁵ mm/mm/°C	1.2		1.4	1.5		8.5	4.92

Flammability

Flame Resistance (0.75 - 3.0mm Thickness):	Flammability Ratings Defined: V-2 burning stops within 30 seconds on a vertical specimen; drips of flaming particles allowed. V-0 burning stops within 10 seconds on a vertical specimen; drips of particles allowed as long as they are not enflamed. HB: slow burning on a horizontal specimen; burning rate < 76 mm/min for thickness < 3 mm or burning stops before 100 mm	UL 94	Class	V-2	HB	HB	HB	HB	V-0	V-0
--	---	-------	-------	-----	----	----	----	----	-----	-----

*Stated temperatures are based on the tensile half-life, e.g. elongation, of the material measured in a controlled environment. Other factors, e.g. the presence of chemicals, may significantly reduce this value

16.1] Polymer Mechanical Properties

	Description	Standard	Units
Physical Properties			
Density	Mass per Volume, also known as 'Specific Gravity'. The units g/cm ³ = g/ml	ISO 1183	g/cm ³ (oz/inch ³)
Water Absorption at 23°C:	The mass of water absorbed from the atmosphere as a % of the total mass:		
24 hours at 50% RH	- 24 hours after moulding.	ISO 62	%
Equilibrium at 50% RH	- When an equilibrium (constant quantity) is reached.	ISO 62	%
Mechanical Properties			
Tensile:	Material properties exhibited whilst under tension. A test specimen is held at both ends and loaded so that the specimen is stretched under tension.		
Modulus	A measure of the stiffness of a material during elastic (non-permanent) deformation. Tensile Modulus = Tensile Stress / Tensile Strain = (Force / Area) / (Increase in Length / Original Length)	ISO 527	MPa
Strength at Yield	The Stress (Force per Area) required to yield a test bar, i.e. to cause plastic (permanent) deformation	ISO 527	MPa
Strength at Break	The Stress (Force per Area) required to break a test bar	ISO 527	MPa
Elongation at Yield	The % increase in length of a test bar at the Yield point, i.e. at the onset of plastic (permanent) deformation. Elongation = Strain x 100	ISO 527	%
Elongation at Break	The % increase in length of a test bar at the break point, i.e. when the material fractures. Elongation = Strain x 100	ISO 527	%
Flexural:	Material properties exhibited whilst under flexure (bending). A test specimen is supported at both ends and a load applied at the mid-point of the specimen in order to cause 3-point bending.		
Modulus	A measure of the stiffness of a material during elastic (non-permanent) deformation. Flexural Modulus = Flexural Stress / Flexural Strain = {(3 x Force x Length) / (2 x Width x Height ³)} / {(6 x Deflection x Height) / (Length ²)} = (Force x Length ³) / (4 x Width x Height ³ x Deflection)	ISO 178	MPa
Strength	Also known as 'Modulus of Rupture' or 'Bend Strength'. The Stress required to break a test bar through 3-point bending.	ISO 178	MPa
Impact Resistance:	The relative susceptibility to fracture under stresses applied at high speeds.		
Charpy at +23°C (73°F)		ISO 179	kJ/m ²
Charpy at -30°C (-22°F)	The energy required to fracture a sample held in a 3-point bending configuration.	ISO 179	kJ/m ²
Charpy at -55°C (-67°F)		ISO 179	kJ/m ²
Charpy notched at +23°C (73°F)		ISO 179	kJ/m ²
Charpy notched at -30°C (-22°F)	The energy required to fracture a notched sample held in a 3-point bending configuration.	ISO 179	kJ/m ²
Charpy notched at -55°C (-67°F)		ISO 179	kJ/m ²
Electrical Properties			
Dielectric Strength (step-by-step) 3.2mm	The voltage required to produce dielectric breakdown of the material, i.e. the maximum voltage the material can insulate per unit thickness.	DIN IEC 60243	kV/mm
Volume Resistivity 3.2mm	The resistance to the flow of electric current through the body of a material.	DIN IEC 60093	x10 ¹¹ ohm-m
Surface Resistivity 3.2mm	The resistance to the flow of electric current along the surface of a material.	DIN IEC 60093	x10 ¹² ohm
Comparative Tracking Index 3.0mm	The voltage which causes tracking after 50 drops of 0.1% ammonium chloride solution have fallen on the material. The results of testing at 3 mm thickness are considered representative of the material's performance in any thickness. Tracking is an electrical breakdown on the surface of an insulating material. A large voltage difference gradually creates a conductive leakage path across the surface of the material by forming a carbonized track.	DIN IEC 60112	V

PA66		POM	PA12		PA12GF		PK		PPS	PEEK	
Dry As Moulded	Conditioned (50% RH)		Dry As Moulded	Conditioned (50% RH)	Dry As Moulded	Conditioned (50% RH)	Dry As Moulded	Conditioned (70°C @ 62% RH)			
1.14 (0.66)		1.41 (0.82)		1.01 (0.58)		1.25 (0.72)		1.24 (0.72)		1.25 (0.72)	1.30 (0.75)
1.1									0.03		0.1
2.4		<0.25		0.7		0.6			0.05		0.1
3000	1400	2550	1600	1100	6700	6000	1400	1400	2300		4000
83	66			40					58		104
		63	50	50	120	105	60	60	55		65-75
4.5	25			12					7		5.0
25	105	60		>50		8	>300	>300	25		10-20
2900	1350	2600	1350	1100	5500	5000	1600	1200	2300		3900
86	22	88	60	45	170	150	60	60	75		134
No break				>100		80	No break	No break	No break		No break
				>100		80	No break	No break			
No break									80		No break
6.6				7		20	15	415	15		5.5
5.3		9		6		15	4.5		8		
											4.9
20						35			13		15.1
400				10		1	100	0.1	650		3.8
						1	10	0.01	3000		>1,9
400-599						600			125		150

16.2] Glass Fibre Yarn - Ø1mm Material Properties

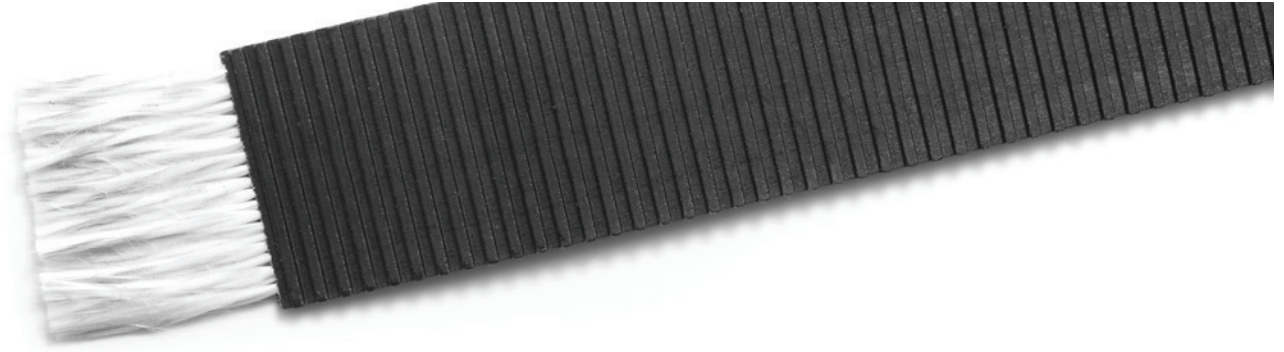

	Description	Units	Description
Physical Properties			
Density	Mass per Volume, also known as 'Specific Gravity'. The units g/cm ³ = g/ml	g/cm ³ (oz/inch ³)	2.60 (1.50)
Moisture Content (ISO 3344)	Moisture content lost after drying at 105°C	%	0.70
Mechanical Properties			
Tensile:	Material properties exhibited whilst under tension. A test specimen is held at both ends and loaded so that the specimen is stretched under tension.		
Strength at Break	The Tensile Strength of an individual yarn at the Break point, i.e. when the material fractures	N	960
Elongation at Break	The % increase in length of an individual yarn at the break point, i.e. when the material fractures. Elongation = Strain x 100	%	2
Thermal Properties			
Melting Point	The temperature at which the Glass melts, i.e. turns from a solid to a liquid	°C (°F)	750 (1382)
Flammability			
Loss on Ignition	The mass of material lost following ignition (volatile substances are burned off)	%	1



17] Chemical Resistance

Please note that in the past HCL have supplied Smart® Band and Smart® Tie in PA11 but in recent years this has been superseded by PA12. Compared with PA11 the chemical resistance data is relatively limited for PA12 however they are widely regarded as being very similar in terms of chemical resistance performance. Chemical resistance data is more available for PA11 and so for the purposes of giving information and comparison, PA11 data has been published in the following sections 17.1] and 17.2].

17.1] Chemical Resistance Overview

17.1.1] PA11

Note: For the purpose of comparison it is interesting to look at the chemical resistance data for PA11 and PA12. This provides relevant performance information and indicates why PA12 is regarded as being nearly equivalent to PA11.

The material absorbs very little moisture, which allows for good dimensional stability of manufactured parts. It has excellent impact strength and is very resistant to abrasion. Resistance to oil based compounds, solvents and salt water is generally considered excellent.

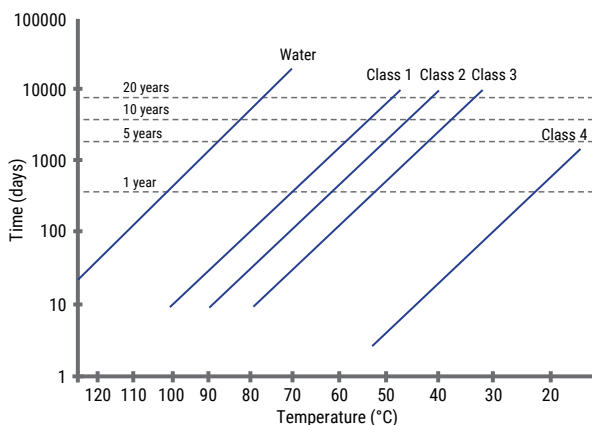

Chemical	Liquid Base	Functions	Compatibility Class
oxypropylated and/or oxyethylated alkylphenols "non ionic surfactants"	hydrocarbon, water/glycol	demulsifier	< water
ethylene oxide/propylene oxide copolymers	hydrocarbon	demulsifier	< water
glycol esters	hydrocarbon	demulsifier	< water
fatty amines	hydrocarbon, water, water/glycol	corrosion inhibitor	class 1
imidazoline derivatives	hydrocarbon, water, water/glycol	corrosion inhibitor	class 1
sulphite derivatives	water, water/glycol	corrosion inhibitor	class 2
bisulphite salts	water	oxygen scavenger	class 2
quaternary ammonium salts, "quats", ammonium salts	water, water/glycol	biocides	< water
aldehydes	water, water/glycol	biocides	class 2
polyacrylates	water, water/glycol	paraffine inhibitors scale inhibitors	class 1
organic phosphonates	water, water/glycol	scale inhibitors corrosion inhibitors	class 3
organic sulfonates	water, water/glycol	scale inhibitors corrosion inhibitors	class 3
hydrochloric acid 15%	water	well stimulation	class 4
hydrofluoric acid 15%	water	well stimulation	class 4

"< water" means that the chemical is less aggressive than water.

17.1.2] PA12

The material has virtually identical properties to PA11. See section 17.1.1

17.1.3] PK

Has a good chemical resistance especially with regard to weak acids, which generally corrode polyamides such as PA12 and PA66. Minor discoloration may occur to PK in these conditions but the strength at break remains constant.

17.1.4] PPS

Is essentially unaffected by a broad class of chemicals at elevated temperatures and for prolonged periods of time. In general, the few classes of compounds that may cause some loss of mechanical properties include strong acids, oxidizing agents, and some amines.

17.1.5] PEEK

Is one of the industry's most chemically resistant plastics and offers very high temperature continuous use performance. It is exceptionally resistant to aggressive chemicals such as organics, acids and bases.

17.2] Permeability

Permeability is an important factor to consider when determining the chemical resistance.

All Smart® polymers have good permeability properties that make them suitable for use in downhole applications.

17.2.1] PA11

	P (bar)/f (bar)	T (°C)	Permeability cm ³ .cm/ cm ³ .s.bar 10 ⁻⁸	Diffusion cm ² /s 10 ⁻⁷	Solubility cm ³ / cm ³ .bar
CH ₄	96	99	3.8	7.3	0.05
	99	99	4.4	6.1	0.07
	103	78	2	2.8	0.07
	97	80	2	3.3	0.06
	101	61	0.8	2.6	0.03
	103	61	0.9	2.2	0.04
	102	41	0.4		
	101	60	0.8	2.2	0.03
CO ₂	40	79	10	4.5	0.22
	39	80	9.4	4.7	0.2
	39	60	4.5	1.9	0.23
	39	61	4.4	2.3	0.19
	41	41	1.5	0.9	0.16
	40/33	80	38	4.5	0.85
H ₂ S	100/47.5	80	67	7.6	0.88
	103/48	80	66	8.2	0.8
	92/47	80	77	9.2	0.84
	41/33	80	43	4.2	1.04
	40/33	80	38	4.5	0.85

Note: Data taken from Arkema – "Rilsan Offshore Fluids and Compatibility Guide"

Fluid	Conditions	Permeation value/cm ³ .cm/ cm ² .s.bar
CH ₄	70°C, 100 bars	9x 10 ⁻⁹
CO ₂	70°C, 100 bars	50x10 ⁻⁹
H ₂ O	70°C, 50 to 100 bars	2x10 ⁻⁶ to 7x10 ⁻⁶
H ₂ S	70°C, 100 bars	1x5x10 ⁻⁷
Methanol	23°C, 1 bar	3.7x10 ⁻⁹

Note: Data taken from Arkema – "Rilsan Offshore Fluids and Compatibility Guide"

Fluid	Permeation value/cm ³ .cm/cm ² .s.bar			
	70°C, 25 bar	70°C, 50 bar	70°C, 75 bar	70°C, 100 bar
CH ₄	0.53x10 ⁻⁷	1.4x10 ⁻⁷	1.9x10 ⁻⁷	1.8x10 ⁻⁷
CO ₂	2.3x10 ⁻⁷	5.8x10 ⁻⁷	7.8x10 ⁻⁷	7.8x10 ⁻⁷
H ₂ O	3.6x10 ⁻⁶	6.5x10 ⁻⁶	3.4x10 ⁻⁶	1.9x10 ⁻⁶

Note: Data taken from Arkema – "Rilsan Offshore Fluids and Compatibility Guide"

17.2.2] PA12

The material has virtually identical permeability properties to PA11.

17.2.3] PPS

The PPS polymer is relatively impermeable to gases, fuels and other liquids compared to other materials. The combination of low permeability and high chemical resistance makes PPS an excellent material where a high gas barrier is needed.

The following bar graphs illustrate the superior performance of PPS.

17.2.3.1] CO2 Transmission Data (cc/sq.m./day)

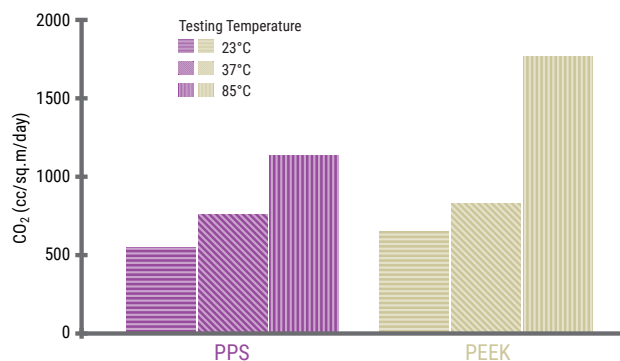

17.2.3.2] Fuel Permeability 60°C, 4 bar

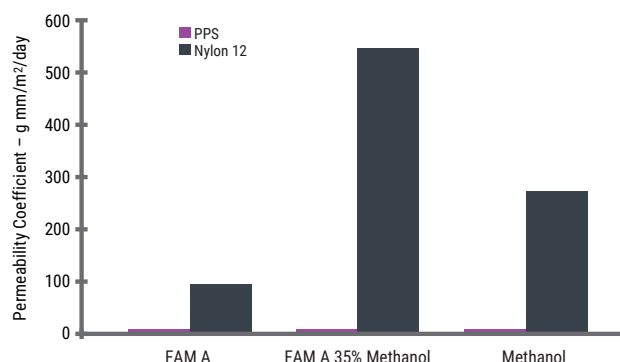

Note: Sample thickness was 0.005 inches

*Note: Data taken from Fortron "Protect Against Sour Gas Corrosive Conditions with Fortron® PPS"

17.3] Chemical Resistance Chart

The following Chemical resistance table helps to specify which polymer is most suitable for the desired application:

Chemical Agent	PA66			POM Performance				PA12			PK		PPS		PEEK		
	Concentration	Temp °C	Performance	Concentration	unknown °C	23°C (73.4°F)	49°C (120.2°F)	82°C (179.6°F)	Concentration	Temp °C	Performance	Concentration	Temp °C	Performance	Concentration	General	
Mineral Acids																	
Boric acid	7%	24	P	100%	G				10% Aqueous	20	G					G	
Carbonic acid	10%	24	G	100%		G								G		G	
Chloroacetic acid	10%	24	P	100%	P				10% Pure	20	P			G		G	
Chlorosulphonic acid	10%	24	P	100%	P									P		G	
Chromic acid - Potassium chromate	10%	24	P	10%	P				1% Aqueous 10% Aqueous	20	L P	10%		30%	80	G	
Hydrochloric acid	2.5%	23	G	20%	G				1% Aqueous	20	L	1%	23	G**	10%	23	G
	5%	77	P	37%	G				10% Aqueous	20	P	10%	80	G**	10%	80	P
	10%	25	P	100%	G									36%		P	
				100%		P											
Nitric acid	10%	23	P	5-10% 50%	P	P			All Concentrations	20	P	10%		10%	40%	G P	
																<10% >10% >20%	
Perchloric acid	10%	24	P	100%	G											G	
Phosphoric acid	5%	98	P	100%	P				10% Aqueous 50% Aqueous	20	L P	5%		50%		G >40	
Sulphur dioxide	100%	38	P	100%	G				<5%	20	L					G	
Sulphuric acid	1%			3%		G			Pure		L	1%	23	G**	10%	23	G
	3%			30%		P			2% Aqueous		P	10%	80	P*	10%	80	G
	10%								10% Aqueous		P	23	23	G**	20%	180	G
	30%	23	P						36% Aqueous		P	80	80	P*	30%	180	G
Sulphurous acid	10%	23	P	100%	G											L	
Mineral Salts																	
Aluminium hydroxide	10%	23	L	10%		G*							23	L*		Sol	
	10%	52	P										80	G*		G	
Alumina sulphate				100%	p									Saturated or boiled solutions		G	
	10%	23	L													Aqueous (Sat)	
	10%	52	P													G	
Ammonium carbonate	10%	23	L	100%	P									Aqueous		G	
Ammonium chloride	10%	52	P	100%	G				10% Aqueous	20	G			Aqueous		G	
Ammonium hydroxide	10%	23	G**	100%	G											L	
	100%	70	P**													Sol	
Ammonium sulphate	100%			100%		G								Aqueous		G	
														Saturated or boiled solutions		Aqueous	
Antimony trichloride	10%	24	P											Aqueous		G	
Barium chloride				100%		G								Aqueous		G	
	10%	24	P											Saturated or boiled solutions		Aqueous	
Barium sulphate	10%	24	G	100%			G									G	
Barium Sulphide	10%	24	L	100%	G									Aqueous		G	
Calcium arsenate																Aqueous	
														Saturated or boiled solutions		G	
Calcium chloride				100%	P				10% Aqueous 20% Alcohol	20	G P			Saturated	80	G	
	5%	60	P													Aqueous	
Calcium hypochlorite	Sat. Sol.	35	P	100%	P									Aqueous		P	
Calcium thiocyanate	50%		P													Aqueous	
Copper chloride	10%	24	P	100%	G									Aqueous		G	
Copper sulphate				100%	P									Aqueous		G	
														Saturated or boiled solutions		Aqueous	
Copper sulphite	10%	24	P													G	
Di-ammonium phosphate														Saturated or boiled solutions		Aqueous	
Hydrogen sulphide	Sat. Sol.	23	P	100%	G									Aqueous		L	
Magnesium chloride				100%		G								Aqueous		G	
Potassium carbonate				100%	G									Aqueous		G	
	20%	98	G													Aqueous	
Potassium chloride	90%	23	G	100%	G									Aqueous		G	
Potassium hydroxide	30%	98	L	100%	G									Aqueous		L	
Potassium nitrate				100%	G				10% Aqueous	20	G			Aqueous		G	
														Saturated or boiled solutions		Aqueous	
Potassium sulphate				100%	G				10% Aqueous	20	G			Aqueous		G	
														Saturated or boiled solutions		Aqueous	
Potassium thiocyanate	Sat. Sol.		P													G	
Sodium carbonate				2%		G			10% Aqueous	20	G			Aqueous		G	
	2%	35	G	2% 20%				G G						Saturated or boiled solutions		Aqueous	
Sodium chloride				Saturated		G			All Concentrations	20	G		23	G		Aqueous	
	10%	23	G	10%				G*				80	80	G*		G	
Sodium hydroxide (Caustic Soda)				1%		G			40% Aqueous	20	G		23	G**	10%	23	G
	10%	70	P**	10%		G						80	80	G*		G	
				10%				G*									
				60%				G*									
Sodium nitrate	5%	24	G	100%	G				10% Aqueous	20	G			Aqueous		G	
Sodium sulphate	90%	24	G	100%	G				10% Aqueous	20	G			Aqueous		G	
Sodium sulphide	90%	24	G						10% Aqueous	20	G			Aqueous		G	
														Saturated or boiled solutions		Aqueous	
Sodium thiosulphate				25%		G			10% Aqueous	20	G			Aqueous		G	
Stannic chloride	10%	24	P**	100%	G											G	
Stannic sulphate	10%	24	P													G	
Triresyl Phosphate	100%	66	G													G	

*Discolouration occurs. **Swelling action. G = Good. L = Limited. P = Poor. †100% unless otherwise stated.

Chemical Agent	Concentration†	PA66		Concentration†	POM Performance				Concentration†	PA12		Concentration†	PK		Concentration†	PPS		Concentration†	PEEK		
		Temp °C	Performance		unknown °C	23°C (73.4°F)	49°C (120.2°F)	82°C (179.6°F)		Temp °C	Performance		Temp °C	Performance		Temp °C	Performance		Temp °C	Performance	General
Trisodic phosphate												Concentrated or boiled solutions									
Zinc chloride				100%	G				10% Aqueous	20	L	Saturated			Saturated	80	G	Aqueous	G		
Mineral bases																					
Ammonia	Sat. Sol. 100%	-33 24	G G	100%	P				10% Aqueous Gaseous All Concentrations	20	G	Concentrated			anhydrous liquid		P	anhydrous liquid	G		
Ammonia solution	10%	24	P									Liquid or gas						Aqueous	G		
Potassium carbonate				100%	G							50%									
Sodium bicarbonate	50%	24	G	100%	G				All Concentrations	20	G	50%			Aqueous	G		Aqueous	G		
Other mineral bodies																					
Agricultural spray solution																					
Bleach (sodium hypochlorite)	5%	23	L	5%		P							23 80	G* G*	5%	80	L	Aqueous	G		
Bromine	100%	24	P	100%	P				All Concentrations	20	P				liquid pure		P	liquid pure	P		
Bromine water	25%	23	G**																		
Carbonated water				100%	G														G		
Chlorine	100%	23	P	100%	P				Pure	20	P				Gas - dry Gas - wet Liquid - pure		P P P	Gas - dry Gas - wet Liquid - pure	G P P		
Chlorine water	Sol. Sat. Sol.	23 23	L P																		
Chlorox	100%	23	G	100%	P																
Fluorine				100%	P										Dry - pure Wet - pure Pure		P P G	Dry - pure Wet - pure Pure	P P G		
Hydrogen																					
Hydrogen peroxide	3% 5%	23 43	G P	10% 50% 100%	P P P				2% Aqueous 10% Aqueous 36% Aqueous	20	P P P				0.5% 30%		L L	0.50% 30%	G G		
Mercury				100%	G				Pure	20	G								G		
Ozone				100%	G				< 1ppm Gaseous Gaseous All Concentrations	20	G P				Wet & Dry		P	Wet & Dry	L		
Oxygen																					
Potassium permanganate	5%	23	P	100%	G				1% Aqueous	20	P	5%			Aqueous		P	Aqueous	G		
Sea water				100%	G														G		
Sulphur									Pure	20	G										
Water				100%		G		G**	Pure	20	G				Distilled		L		G		
Organic bases																					
Aniline						Pure		G**	Pure	20	L	Pure							G		
Diethanolamine				100%	G							20%									
Pyridine				100%	G				Pure	20	G	Pure			Pure		L	Pure	G		
Urea				100%	G				20% Aqueous	20	G							Aqueous	G		
Organic acids and anhydrides																					
Acetic acid	5%	23	P**	5% 20% 80%	G G P				10% Aqueous 40% Aqueous Pure	20	P P P		23 80	G* G*	100%		G	Pure	G		
Acetic anhydride				100%	P				Pure	20	P				Pure		G				
Benzoic acid	10%	23	P	100%	G				Pure	20	L						G	Aqueous Saturated	G		
Butyric acid	10%	24	P	100%	G				Pure	20	L				Aqueous		G	Aqueous	G		
Citric acid	10%	24	P	10%		G									Aqueous		G	Aqueous	G		
Formic acid		23	P	100%	G				10% Aqueous 40% Aqueous 85% Aqueous	20	P P P				Aqueous Pure		G	Aqueous Pure	G L		
Glycolic acid	70%		P	100%	G										Aqueous		G				
Lactic acid	10%	35	G	100%	G				5% Aqueous 50% Aqueous 90% Aqueous	20	L P P				Aqueous		G	Aqueous	G		
Oleic acid				100%		G		G	Pure	20	G										
Oxalic acid				Cold	G				10% Aqueous	20	L				Aqueous (Sat)		G	Aqueous (Sat)	G		
Picric acid				100%	G																
Stearic acid				100%	G													G			
Tartaric acid				100%	G				Pure	20	G				Aqueous		G	Aqueous	G		
Uric acid																					
Hydrocarbons																					
Acetylene				100%	G														G		
Benzene	100%	23	G	100%		G**			Pure	20	G				Pure		L		G		
Butane				100%	G				Pure	20	G				Gas & Liquid		G	Gas & Liquid	G		
Cyclohexane				100%		G			Pure	20	G				Pure		G	Pure	G		
Decaline									Pure	20	G										
FORANE® 12 - Dichlorodifluoromethane																					
FORANE® 22																					
R-134a - Tetrafluoroethane				100%		G		G							100%	100	G				
Heptane									Pure	20	G		23 80	G* G*	Pure		G	Pure	G		
Hexadecane	10%	23	G**	100%	G																
Methane				100%		G									Pure		G	Pure	G		
Naphthalene				100%		G		G	Pure	20	G										
NUJOL	100%	70	G	Liquified	G																
Propane				100%	G				Pure	20	G				Gas & Liquid		G	Gas & Liquid	G		
Styrene				100%		G		G**	Pure	20	G								G		
Toluene	100%	50	G	100%	G				Pure	20	G		23 80	G G*		80	L	Pure	G		
Xylene	100%		G						Pure	20	G		23	G		80	L	Pure	G		
Alcohols																					
Benzyl alcohol									Pure	20	P								Pure	G	

*Discolouration occurs. **Swelling action. G = Good. L = Limited. P = Poor. †100% unless otherwise stated.

Chemical Agent	Concentration†	PA66		Concentration†	POM Performance				Concentration†	PA12		Concentration†	PK		Concentration†	PPS		Concentration†	PEEK	
		Temp °C	Performance		unknown °C	23°C (73.4°F)	49°C (120.2°F)	82°C (179.6°F)		Temp °C	Performance		Temp °C	Performance		Temp °C	Performance		General	
Butanol	100%	50	G	100%	G			Pure	20	G					80	G	Aqueous	G		
Ethanol	100%	23	G**	100%		G	G**	Pure	20	G				5%	80	G	Pure	G		
Ethanol	100%	50	G**																	
Ethylene glycol	50%	23	G	50%										Pure		G	Pure	G		
Glycerin				100%	G			Pure	20	G				Aqueous		G	Aqueous	G		
Glycol								Pure	20	G					120	G	Aqueous	G		
Methanol	100%	23	G**	100%	G								23	L		60	L		G	
Methanol (60%)																55	G		G	
Methanol (15%)																60	G		G	
Aldehydes and ketones																				
Acetone	100%	23	G	100%		G**		Pure	20	G			23	G*	100%	55	G	Pure	G	
Acetone	100%	50	G																	
Acetaldehyde	100%	52	L					40% Aqueous	20	L							L	Pure	G	
Formaldehyde	38%	23	G	40%		G		40% Aqueous		P					Aqueous		L	Aqueous	L	
Formaldehyde				100%	G										Pure		G	Pure	G	
Cyclohexanone								Pure	20	G					Pure		G	Pure	G	
Methyl ethyl ketone - Butanone				100%	G			Pure	20	G					100%	58	G	Pure	L	
Methyl isobutyl ketone	100%	23	G																	
Benzaldehyde				100%	G			Pure	20	P					Aqueous		L	Aqueous	G	
Chlorinated solvents																				
AROCOLOR 1242	100%	23	G					Pure	20	G										
Carbon tetrachloride	100%	23	G	100%		G	G**								Pure		L	Pure	G	
Carbon tetrachloride	100%	50	G																	
Dichloroethane	100%	66	G	100%		G**							23	L	Pure		L	Pure	G	
Hexafluoroisopropanol	100%	23	P																	
Methyl bromide				100%	P															
Methyl chloride	100%	23	L	100%	G										Pure		L	Pure	G	
Methyl trichloride	100%	23	G																	
Methylene chloride	100%	23	L	100%	G										Pure		L	Pure	L	
Tetrafluoropropane			L																	
Trichloroethylene				100%	P									23	L	Pure		L	Pure	G
Trichloroethylene														80	P**					
Trichloroethane	100%	72	G	100%	G			Pure	20	G			23	G**	100%	100	G			
Trichloroethane														80	G**					
Perchloroethylene				100%	G			Pure	20	P					Pure		L	Pure	G	
Phenols	5%	23	P	5%		G**									Aqueous (Sat)		G	Aqueous (Sat)	L	
Various organic bodies																				
Anethol																				
Carbon sulphide															Pure		G			
Dibromoethane	100%	50	L																	
Dimethyl formamide				100%	P			Pure	20	G				23	L**	Pure		L	Pure	G
Dimethyl formamide														80	P					
Ethylene oxide				100%	P															
Furfural				100%	G			Pure	20	L										
Glucose				100%	G										Aqueous		G	Aqueous	G	
Glycol chlorohydrine																				
Nitromethane	100%	23	G	100%	G			Pure	20	G										
2-Nitropropane	100%	72	G																	
Tetraethyl lead																		L	G	
Salts, esters, ethers																				
Amyl acetate	100%	98	P	100%		G		Pure	20	G					Pure		G	Pure	G	
Butyl acetate				100%	G			Pure	20	G				23	G	100%	80	G	Pure	G
Butyl acetate														80	G**					
Diethylene glycol	90%	24	G	100%		G														
Dimethyl ether				100%		G**														
Diethyl ether								Pure	20	G										
Diocetyl phosphate															100%	23	G	Pure	G	
Diocetyl phthalate				100%		G**	G**								Pure		G			
Ethyl acetate	100%	50	G	100%	G			Pure	20	G					100%		G	Pure	G	
Fatty acid esters				100%	G															
Methyl acetate															Pure		G	Pure	G	
Methyl sulphate																				
Sulphuric ether																				
Tributyl phosphate						G									Pure		G			
Tricresyl phosphate	100%	66	G												Pure		G			
Miscellaneous products																				
Antifreeze	100%	104	L	100%														L	G	
Automatic transmission fluid				100%														G	G	
Beer				100%		G		Commercial Grade	20	G								G	G	
Brake Fluid						G		G**	Commercial Grade	20	G					80	G		G	
Cider				100%	G													G	G	
Coal gas																		G	G	
Crude oil																		G	G	
Detergent				100%				G*										G	G	
Diesel				100%				G**	Commercial Grade	20	G					80	G		G	
Fruit juice									Commercial Grade	20	G							G	G	
Gasohol				100%		G	G													
Grease				100%														G	G	
Kerosene				100%														G	G	
Lanolin suspension	10%	35	G																	
2,4-D Lindane																				
Linseed Cake	100%	82	G	100%																
Milk				100%	G				Commercial Grade	20	G							G	G	
Motor oil				100%		G	G											80	G	G
Mustard				100%	G														G	

*Discolouration occurs. **Swelling action. G = Good. L = Limited. P = Poor. †100% unless otherwise stated.

Chemical Agent	PA66		Concentration†	POM Performance				PA12		Concentration†	PK		Concentration†	PPS		Concentration†	PEEK
	Concentration†	Temp °C		Performance	unknown °C	23°C (73.4°F)	49°C (120.2°F)	82°C (179.6°F)	Temp °C		Performance	Temp °C		Performance	Temp °C		Performance
Naphtha	100%	98	G**	100%													G
Oil								Commercial Grade	20	G			60	G			G
Oxyquinoline (agricultural spray)																	
Premium grade gasoline				100%			G**	Commercial Grade	20	G				G			G
Regular grade gasoline				100%			G**	Commercial Grade	20	G			80	G			G
Soap Cleanser				100%													
Stearine																	
Turpentine				100%			G										
Vinegar				100%	G			Commercial Grade	20	L							G
Wine								Commercial Grade	20	G				G			G

*Discolouration occurs. **Swelling action. G = Good. L = Limited. P = Poor. †100% unless otherwise stated.

18] Ageing

18.1] Ageing in Water (pH7)

Water is the critical chemical medium for Polyamides (such as PA12). Deionised water (pH = 7) does not contain salts (such as Sodium Chloride), so the probability of chemical interaction between the water molecules and the amide groups is maximised. Salt water contains salts which do not interact with the Polyamide. The salts bind a certain amount of water by forming a shell of water molecules around each salt ion. The presence of salts therefore reduces the speed of the water absorption of the Polyamide and therefore the effects of ageing.

18.1.1] Ageing Comparison for PA12 Material (PA12GF against PA11GF)

Traditionally PA11 has been used in many subsea applications and has been well proven to resist subsea environments. In recent years PA12 has become very effective in replacing PA11 for many applications including oil and gas. The following graph gives a direct comparison between the two materials showing that the ageing of each polymer in water is very similar. For this application it can therefore be determined PA11 applications can be substituted for PA12.

Prediction of half life time, intermediate results

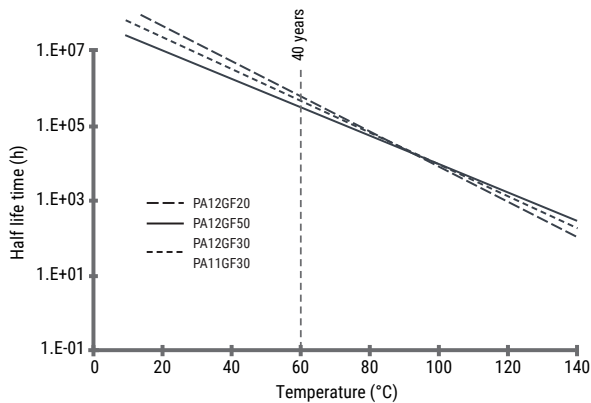

Note
 - Graph lines are extrapolated from pertinent high temperature test data.
 - 50% of the initial fracture value is defined as the half life time.
 - At 60°C a half life time of 40 years is expected for polyamide 12.

18.2] Hot Ageing in Air

18.2.1] PA12

High temperature applications can have a detrimental effect on polymers producing accelerated oxidization of the polymer. PA12 is very resistant to this type of degradation and the following graphs give results for tensile strength and elongation for 110, 130 and 150°C air temperatures.

PA12 – Heat Ageing – Hot air 110°C Tensile Strength

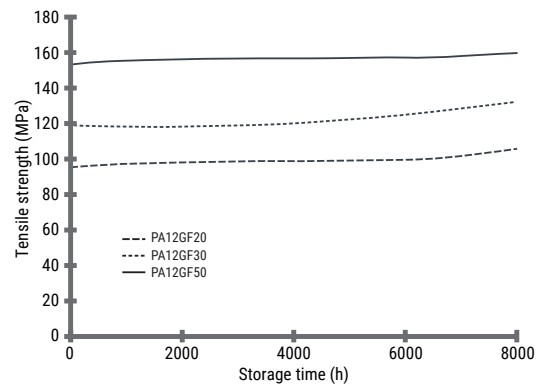

PA12 – Heat Ageing – Hot air 110°C Tensile Elongation

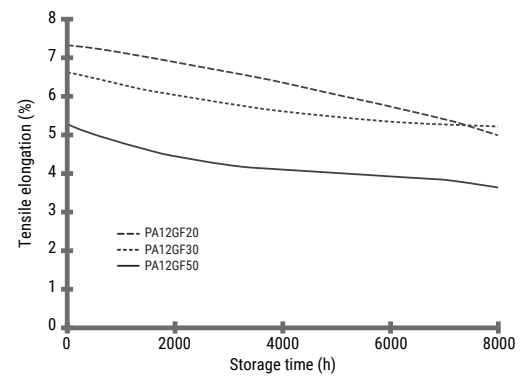

PA12 – Heat Ageing – Hot air 130°C Tensile Strength

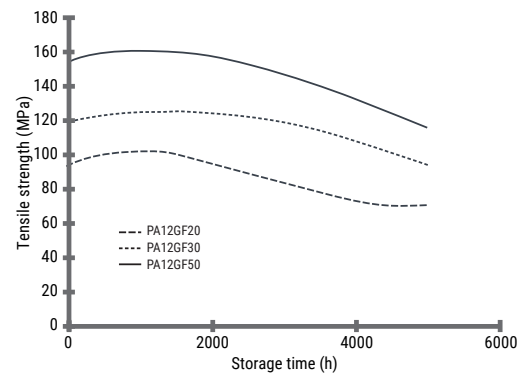

PA12 – Heat Ageing – Hot air 130°C Tensile Elongation

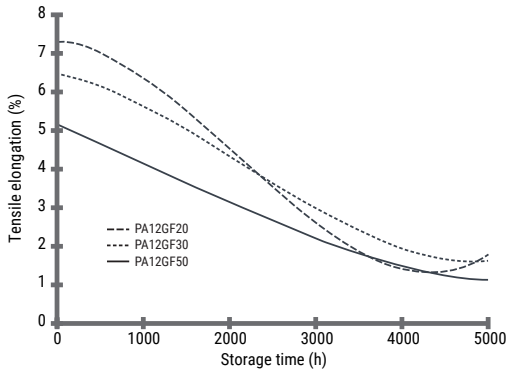

PA12 – Heat Ageing – Hot air 150°C Tensile Strength

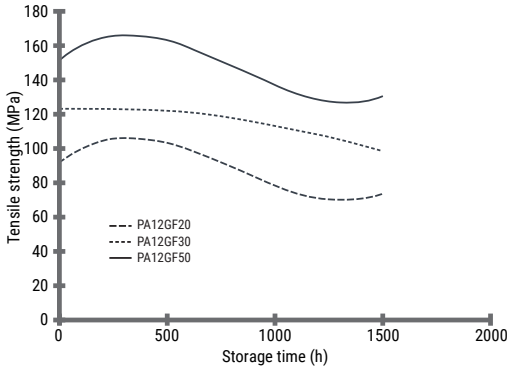

PA12 – Heat Ageing – Hot air 150°C Tensile Elongation

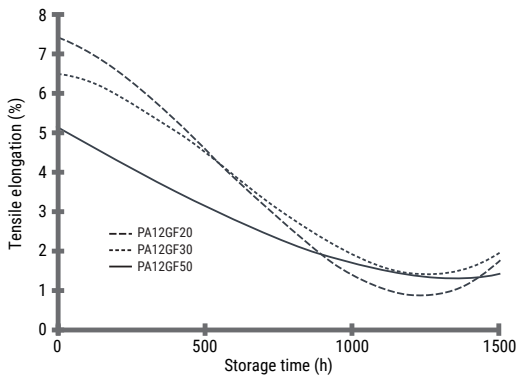

18.3] Fresh Water Immersion

It is generally considered that hygroscopic saturation occurs within 6 months of water submersion. Smart® Band 32mm samples were immersed in fresh water for at least 8 months and then tested to determine the effects of moisture absorption on Tensile strength. A PA11GF result is included to give a direct comparison with PA12GF

18.3.1] Fresh Water Immersion Smart® Band Hybrid System Tensile Tests

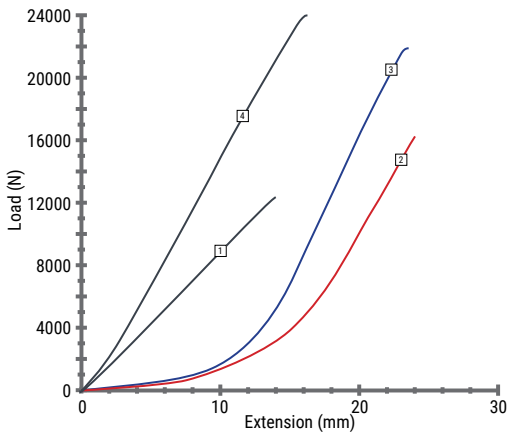

Line No	Band Size	Band Material	Break Strength	Water Absorption Time
			N (kgf) [lbf]	Months
1	19mm (¾")	PA12GF	12339 (1258) [2774]	36
2	32mm (1¼")	POM	16700 (1702) [3745]	8
4	32mm (1¼")	PA12GF	23836 (2431) [5359]	36

18.4] Oil Immersion – (Mineral Oil – Isovoltime at 110°C)

18.4.1] Smart® Tie 20mm

The following products were immersed in mineral oil for different periods of time. They were removed and allowed to cool to 20°C and then tested for system tensile strength.

Material	Days	System Tensile Strength at Break Strength
		N (kgf) [lbf]
PA66	1	8374 (854) [1883]
	7	FAILED*
	28	FAILED*
PA12	1	4983 (508) [1120]
	7	5261 (536) [1183]
	28	FAILED*
PPS	1	6189 (631) [1391]
	7	6354 (648) [1428]
	28	6681 (681) [1502]
PK	1	7329 (747) [1647]
	7	5630 (574) [1266]
	28	FAILED*

*Where the result is classed as "Failed" it is where no tensile test was carried out. The product failed during fitting to the test diameter.

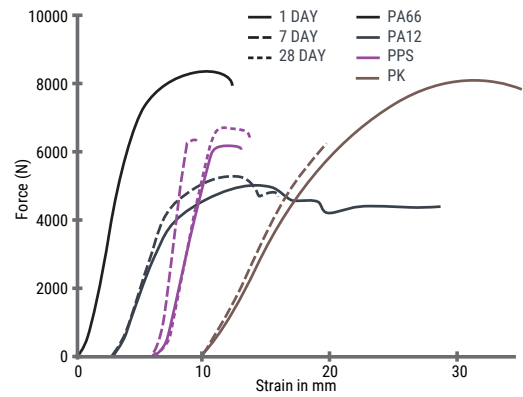

Note: Curves offset along x-axis in 2.5mm intervals for clarity

18.4.2] Smart® Tie 32mm

Material	Days	System Tensile Strength at Break Strength
		N (kgf) [lbf]
PA12	1	9999 (1020) [2248]
	7	10263 (1047) [2307]
	28	2489 (254) [560]
PPS	1	12101 (1234) [2720]
	7	12123 (1236) [2725]
	28	12009 (1225) [2700]
PK	1	15054 (1535) [3384]
	7	6310 (643) [1419]
	28	1274 (130) [286]

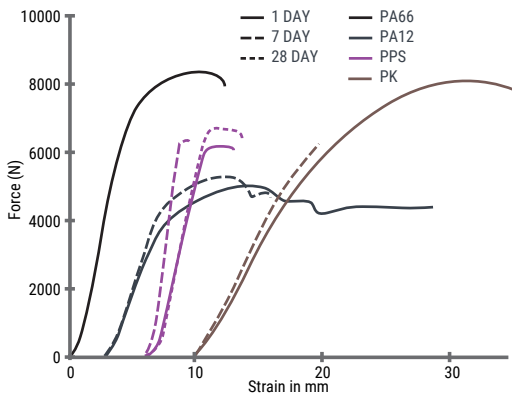

Note: Curves offset along x-axis in 5mm intervals for clarity

Refer to 17.2.3.2] Fuel permeability 60°C, 4Bar for further information relating to the PPS material's suitability for use with oils and fuels due to very low levels of permeability.

Where applications involve immersion in hot oil and fuel, PPS is the recommended material choice.

18.5] CO₂ (Carbon Dioxide), H₂S (Hydrogen Sulphide) and NORSOK M-710

Acidic (sweet) gas and Sour gas are often associated with geological drilling operations in the exploration and production sector of the oil and gas industry. This section deals with the resistance to CO₂ acidic (sweet) gas and H₂S sour gas.

The presence of these gases can create a hostile environment and have a detrimental effect on downhole hardware. The polymers selected for Smart® Protector and Smart® Tie have good resistance to these gases. The resistance increases in order of the polymer choice i.e. PA66, PA12 & PA11, PK, PPS and with PEEK having the best resistance.

Although there is not as much data available for the resistance of PA66 to sour and sweet gas the general chemical resistance at room temperature to CO₂ and H₂S is classed as good.

However where there are concerns about the concentration levels of these gases especially at higher temperatures then other polymer options from the Smart® products range should be chosen.

Specifically the NORSOK M-710 qualification requires that all sub-components of oilfield equipment must be approved to stated specifications. Specifically, materials are rigorously tested and approved based on numerous criteria such as Explosive Decompression Resistance (EDR), sour and sweet gas ageing, compression set tests, and material property tests.

18.5.1] PA11 and PA12

PA11 shows good resistance to sour and sweet gas environments.

The graphs below give the resistance of the polymers when in contact with CO₂ in various guises.

This is data for PA11 but can also be used to give an indication of PA12 performance in similar conditions.

18.5.1.1]

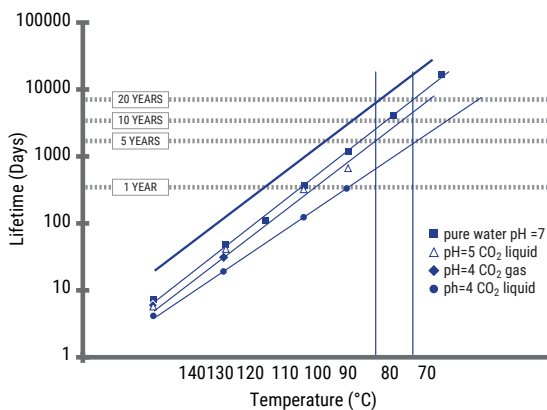

18.5.1.2]

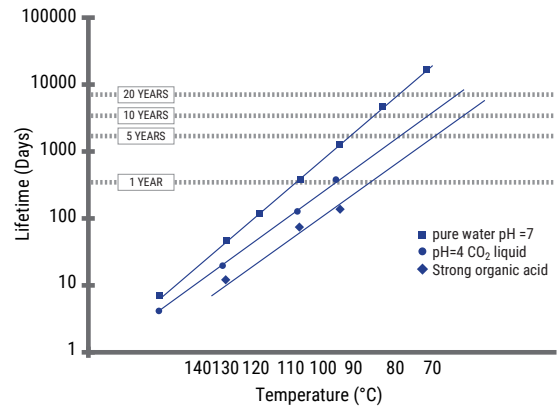

Note: Data taken from Arkema – "Rilsan Offshore Fluids and Compatibility Guide"

18.5.1.3]

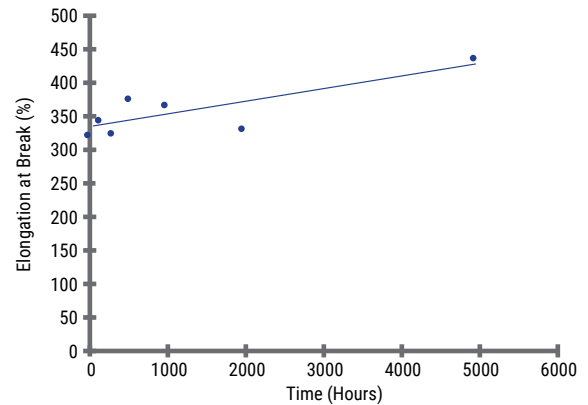

Table comparing initial and aged mechanical properties

	Elongated at break (%)	Stress at rupture (Mpa)	Stress at yield (Mpa)	Elongation at yield (%)	Tensile modulus (Gpa)
Initial sample	359 ± 48	42.0 ± 3,0	-	-	2.78 ± 0.008
Aged sample	315 ± 38	46.7 ± 8,3	27.7 ± 0.5	42.4 ± 0.6	2.82 ± 0.02

Note: Data taken from Arkema – "Rilsan Offshore Fluids and Compatibility Guide"

18.5.2] PA11 & PPS

The following graph gives predicted service lifetimes for PPS and PA11 against temperature. The results illustrate the superior performance of PPS and should be the considered material for highly aggressive sweat and sour applications. PA12 regarded as similar to PA11 would not be recommended in applications experiencing high levels of sweat and sour gases.

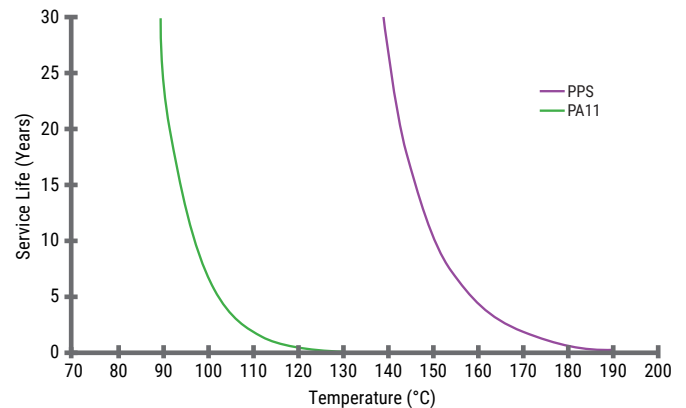

*Lifetime defined as tensile strength reducing by 50% for PPS elongation reducing by 50% for PA11

Note: Data taken from Fortron "Protect Against Sour Gas Corrosive Conditions with Fortron® PPS"

18.5.3] PPS

PPS has very good resistance to sour and sweet gases and is covered in section 17.2 where NORSOK M-710 and Permeability data is available.

18.5.4] PEEK

Tests have been performed to simulate sour and sweet gas environments. The following graphs show results from tests based on NORSOK M-710 but more aggressive. They show that PEEK has robust performance in sour and sweet environments at concentrations of 20% H₂S at 170°C (338°F). They therefore fulfil the NORSOK M-170 acceptance criteria for sour ageing.

18.5.4.1] Tensile strength of PEEK exposed at 170°C (338°F)⁽¹⁾

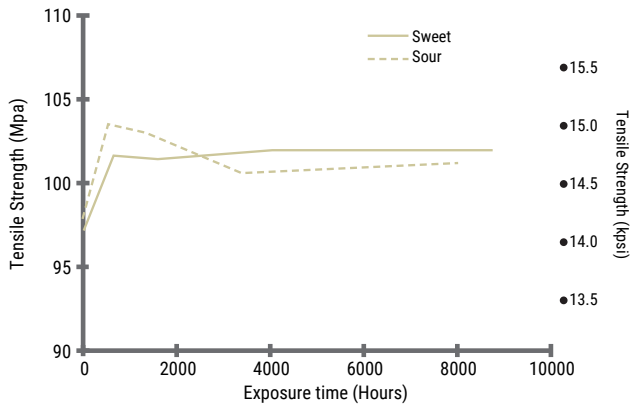

⁽¹⁾ Tested at 50 mm/min (2 in./min)

18.5.4.2] Tensile elongation of PEEK exposed at 170°C (338°F)⁽¹⁾

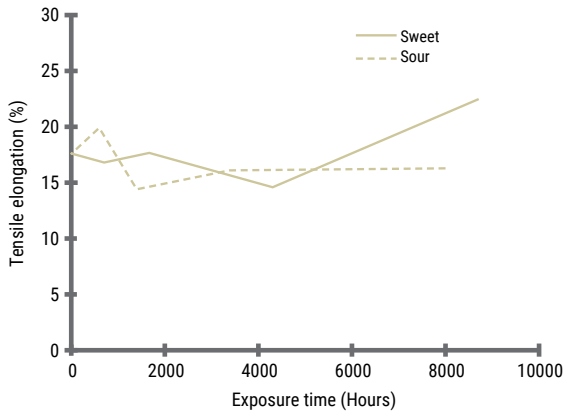

⁽¹⁾ Tested at 50 mm/min (2 in./min)

18.5.4.3] Tensile modulus of PEEK exposed at 170°C (338°F)⁽¹⁾

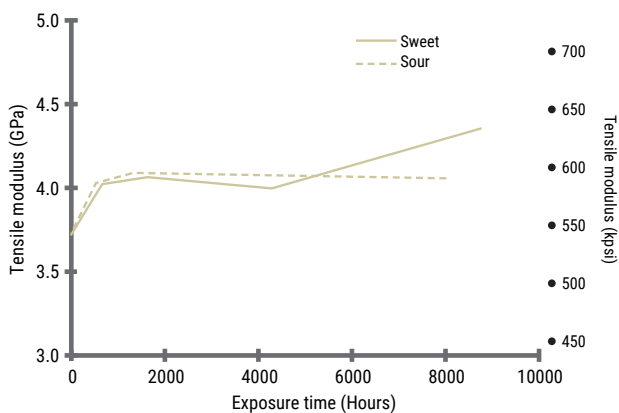

⁽¹⁾ Tested at 50 mm/min (2 in./min)

18.5.4.4] Tensile strength of PEEK after high temperature ageing in sour environment⁽¹⁾

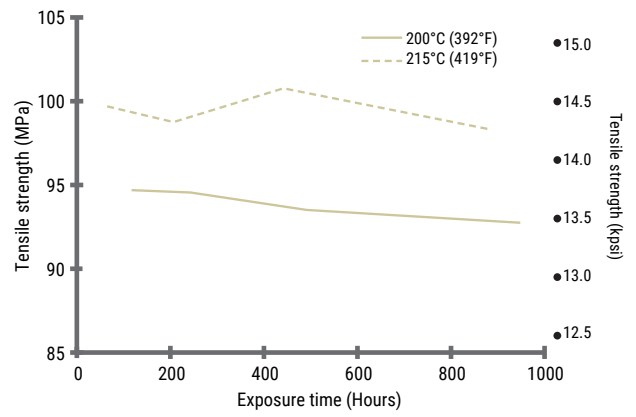

⁽¹⁾ 200°C samples tested at 5 mm/min (0.2 in./min)

18.5.4.5] Tensile elongation of PEEK after high temperature ageing in sour environment⁽¹⁾

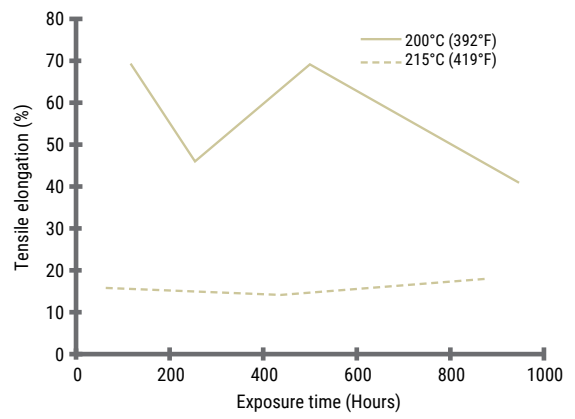

⁽¹⁾ 200°C samples tested at 5 mm/min (0.2 in./min),
215°C samples tested at 50 mm/min (2 in./min)

18.5.4.6] Tensile modulus of PEEK after high temperature ageing in sour environment⁽¹⁾

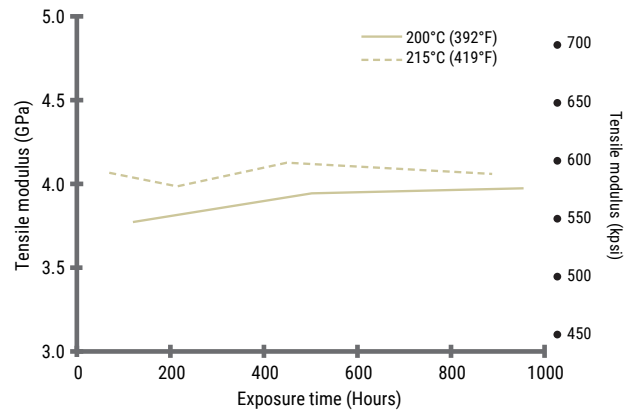

⁽¹⁾ 200°C samples tested at 5 mm/min (0.2 in./min),
215°C samples tested at 50 mm/min (2 in./min)

Note: Data taken from Solvay – "Ketaspire® PEEK Design & Processing Guide"

When exposed to weathering, polymers have a natural tendency to photo-oxidise and depolymerise to their natural elemental forms. There are variations in natural weathering depending on the intensities of the following components:

1. Solar Radiation (UV)
2. Moisture
3. Heat
4. Pollutants e.g. ozone and acid rain
5. Salt Water

The combination of more than one of these factors can also lead to accelerated degradation and ageing.

Weathering intensity varies widely around the world, and may also vary from year to year for a given location, depending on weather patterns. Weather in a subtropical climate, such as Florida, may have twice the effect on a polymer as a more northerly location. A drier climate, such as Arizona, may have increased UV radiation, but because of the lower humidity, the effects of weathering on a polymer will not be so severe. It is impossible to give a precise indication of the effects of weathering in a given location, but by using natural outdoor and accelerated tests, certain predictions can be made.



Photo courtesy of Groupe Courbis
Location: Malaysia

The carbon black additive in Smart® Band and Smart® Tie products, acts as a very good UV stabiliser. Heat-stabilised grades, usually using a copper based additive, also provide further protection against photo-oxidative degradation by shutting down free radicals. This combination of inhibitors helps to give the polymers many years of life.

Estimated Polymer life expectancy when exposed to weathering

Materials all black	Life in Hot climates	Life in Temperate Climates
	YRS – Approx	YRS – Approx
PA66	10+	15+
POM	15+	20+
PA12	15+	20+
PA12GF	15+	20+
PA11GF	15+	20+
PA11	15+	20+
PPS	10+	15+
PEEK	5+	8+

19.1] PA66

Compared with other polymers, PA66 naturally exhibits a high resistance to weathering and UV degradation, even in its neat state. The graphs below, show the reduction in Tensile strength and Elongation at break of PA66, over a 2000 hour period in a weathering chamber. The accelerated weathering is achieved by wet and dry cycles and continuous UVA (320nm) exposure. The dry cycles last for 8 hours at 70°C, and the wet cycles for 4 hours.

PA66 – Reduction in Tensile strength, due to accelerated weathering

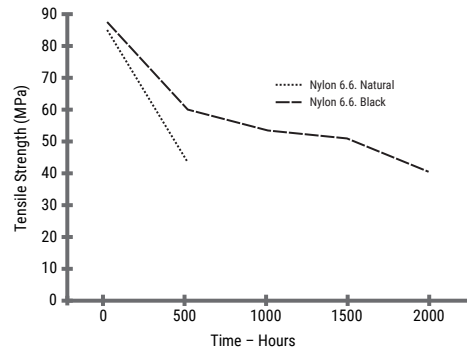

PA66 – Reduction in Elongation at break, due to accelerated weathering

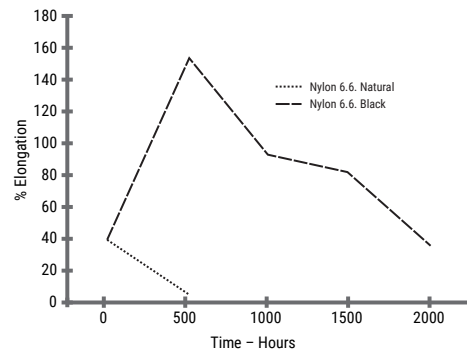

Conclusion

- The degradation caused by weathering, in both the black and natural PA66 tends to reduce the Tensile strength and the Elongation at break of the material over time. This makes the polymer weaker and more brittle.
- The carbon black UV stabiliser gives a huge increase in weathering resistance to PA66.
- It is important to note that the sharp fall in Tensile strength and increase in Elongation at break of Black PA66 from 0 - 500 hours, is largely due to a conditioning effect (taking on moisture). However, the UV degradation that occurs in the natural material during this time is enough to annul the conditioning effect and to reduce the Elongation at break to almost zero.

19.2] POM (Acetal)

When POM (Acetal) is exposed to UV radiation, a white deposit of degraded material forms on its surface, known as 'chalking'. There is a consequential loss of gloss and change in colour, as well as a deterioration in mechanical properties. The graphs below, show the effects of weathering on the Tensile Strength and Elongation at break of POM (Acetal), through natural weathering and an accelerated test.

Outdoor Weathering Tests – Central European Climate

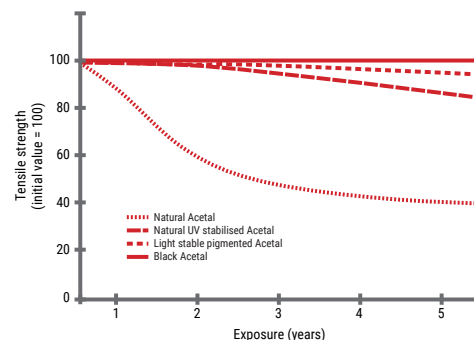

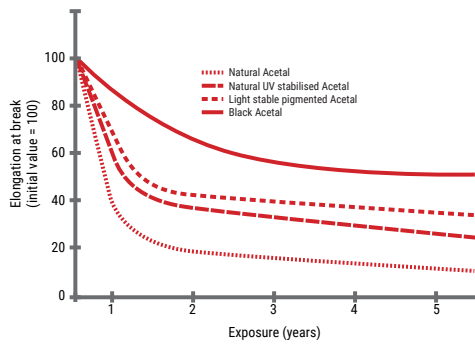

Accelerated Weathering Tests – Xenotest 1200 Environmental Weathering Chamber

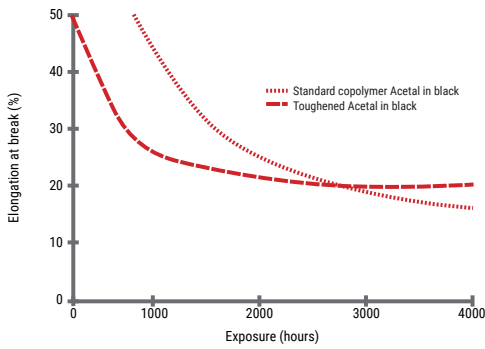
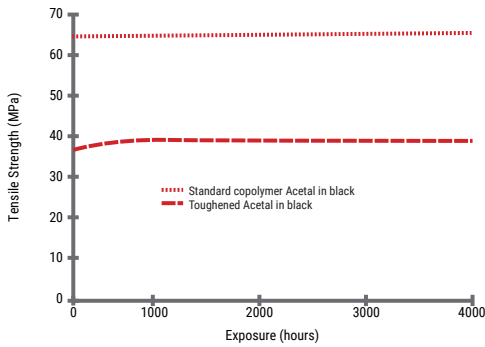

Conclusion

- The degradation caused by weathering, in both the black and natural POM (Acetal) tends to reduce the Tensile strength and the Elongation at break of the material over time. This makes the polymer weaker and more brittle.
- The carbon black UV stabiliser gives a huge increase in weathering resistance to POM (Acetal).

19.3] Weathering Comparison for PA12 and PA11

Note. The information in this section is provided by Arkema.

The following data gives evidence that black PA11 is particularly resistant to degradation from the combined effect of the sun's rays and rain water. Black extruded tubes, 6 inch diameter x 8mm wall thickness; were tested at the following outdoor sites:

Serquigny, France	Moderate, moist climate. Typical of central Europe.
Bandol, France	Warm, moist climate. Typical of Mediterranean.
Iguazu, Brazil	Tropical climate with high sunlight irradiation.
Pretoria, South Africa	Hot, dry climate.

19.3.1] PA11 – The effect on Tensile strength, due to accelerated weathering

This section gives real life weathering data for PA11 in 4 different parts of the world. Black extruded tubes, 6 inch diameter x 8mm wall thickness; were tested at the following outdoor sites:

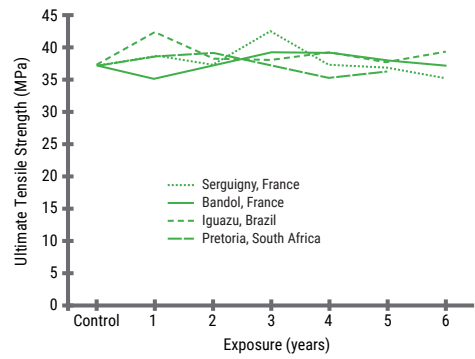

19.3.2] PA11 – The effect on Elongation at break, due to accelerated weathering

This section gives data from comparison tests between PA12 and PA11.

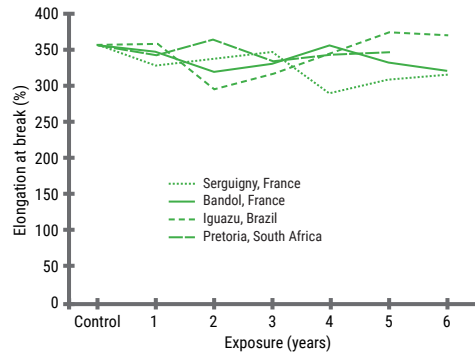

Conclusion

- The degradation to black PA11 caused by weathering, can be seen to be minimal during the above tests. This gives great confidence that the life expectancy of PA11 is far longer than the exposure periods shown above.

UV weathering tests were conducted on samples of the black PA12 & PA11 materials used to manufacture Smart® Band products, according to ISO 4892-2, using a Ci4000 weatherometer. The test conditions were:

- Irradiance at 340 nm: 0.5 W/m²
- Cycle: 102 min dry/18 min water spray
- Black-standard temperature: 65°C ± 3°C
- Relative humidity 65% ± 5% .

19.3.3] PA12 – The effect on Tensile strength, due to accelerated weathering

In light of the performance of PA11 in terms of real life weathering outlined in sections 19.3.1] and 19.3.2] it seems reasonable to directly compare PA11 with PA12. The following two sections give a direct weathering comparison between PA11 and PA12 using accelerated test methods. The objective is to prove that PA12 is similar to PA11 and therefore confidence can be gained for using PA12 in long term outdoor applications.

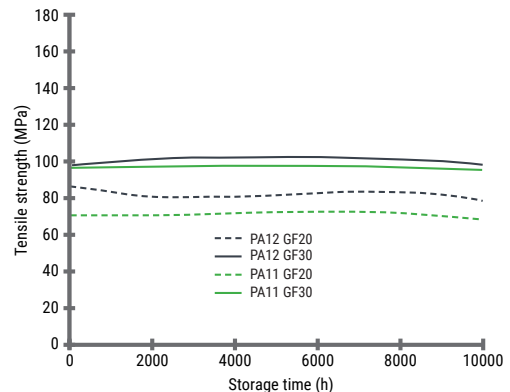

19.3.4] PA12 – The effect on Elongation at break, due to accelerated weathering

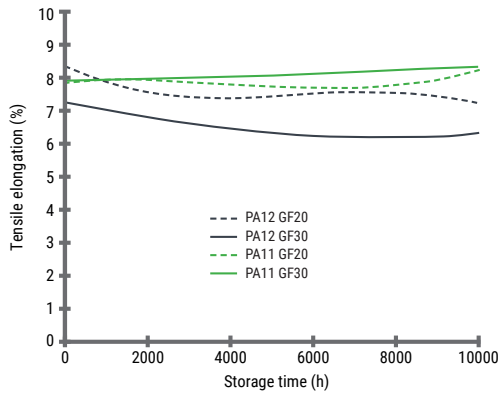

Conclusion

- The weathering resistance of black PA12 and PA11 can be seen to be virtually identical.
- Both black PA12 and PA11 showed minimal changes in properties when subjected to accelerated weathering.

19.4] PK

UV Testing was conducted according to ASTM-G154, with cycles of 8 hours UV (UVA-340 Lamp; 340nm; 0,77 W/m²) at 60°C followed by 4 hours condensation at 50°C.

19.4.1] PK – The effect on Tensile strength, due to accelerated weathering

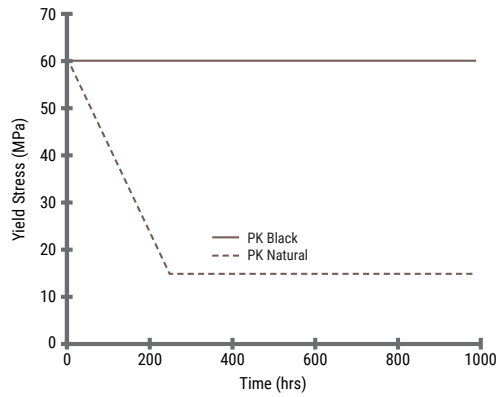

19.4.2] PK – The effect on Elongation at break, due to accelerated weathering

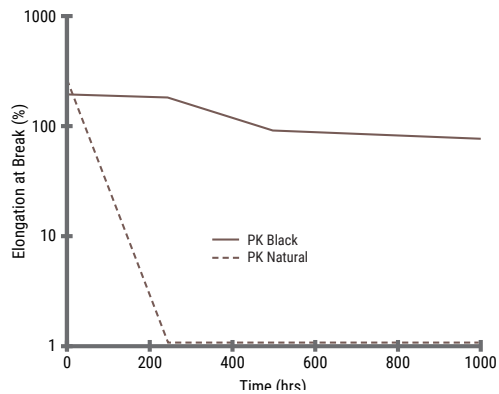

Conclusion

- Black PK has much greater Weathering resistance than natural PK.
- Weathering does not affect the Tensile strength of black PK.
- Weathering causes a slight decrease in the Elongation at break of black PK.

19.5] PPS

UV weathering of Smart® Tie samples was performed according to SAE J1960 to determine effect of mold temperature on Smart® Tie properties:

SAE J1960 Weathering Conditions

Lamp	Xenon
Wavelength	340 nm
Total Cycle Time	200 min
Light Cycle	120 min light 60 min dark
Water Spray	80 min spray 100 min none
Black Panel Temperature	70°C Light Cycle 38°C Dark Cycle
Humidity	50% Light Cycle 95% Dark Cycle

19.5.1] PPS – The effect on Tensile strength, due to accelerated weathering

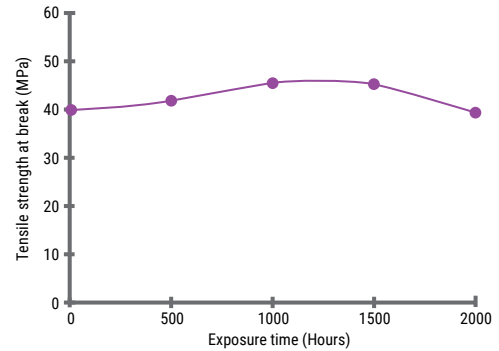

19.5.2] PPS – The effect on Elongation at break, due to accelerated weathering

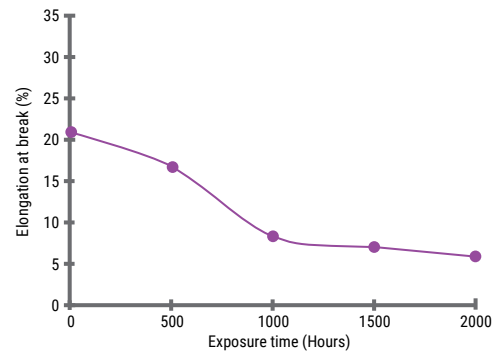

Conclusion

- Weathering has a small effect on the Tensile strength of black PPS.
- Weathering causes a significant reduction in the Elongation at break of black PPS.

19.6] PEEK

19.6.1] PEEK – The effect on Tensile strength, due to accelerated weathering

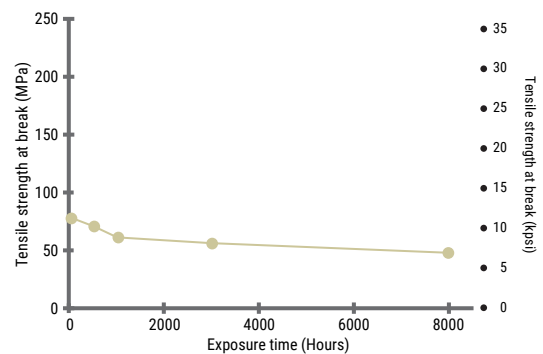

19.6.2] PEEK – The effect on Tensile Modulus, due to accelerated weathering

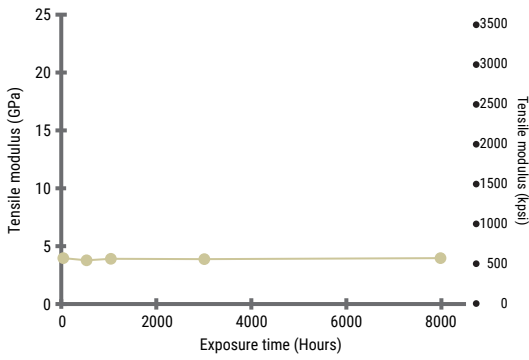

19.6.3] PEEK – The effect on Elongation at break, due to accelerated weathering

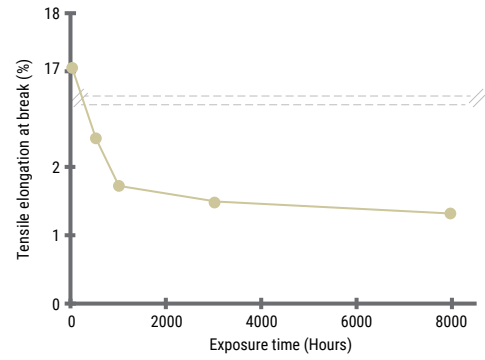

Conclusion

- PEEK is affected by simulated weathering. The primary effects are yellowing, loss of surface gloss, and a loss of ductility. For applications that will be exposed to direct sunlight, it is recommended that parts made of PEEK be painted or pigmented black.

20] Well Flushing

20.1] Advantages of Polymer Products

In extreme conditions it is possible that bands and clamps can be stripped off the downhole tube. This can have a detrimental effect on the well causing damage to pumps and associated equipment. Of particular concern is stainless strapping which is difficult to remove being non-magnetic.

With this in mind Smart® Ties have been successfully used and are more easily flushed out having a density of just over 1 g/cm³.

The following photos show steel strap trapped in a Downhole application:

20.1.1] Trapped Steel Strap in Downhole Tube

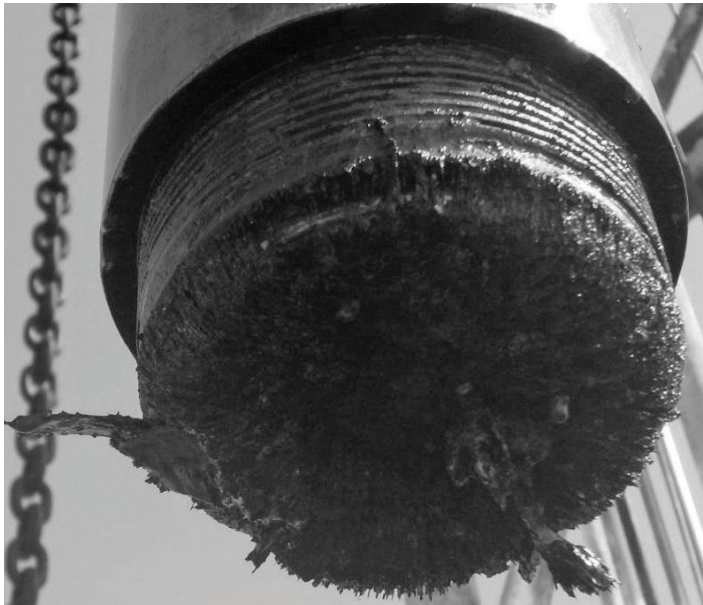

20.1.2] Trapped Steel Strap in Downhole Catcher

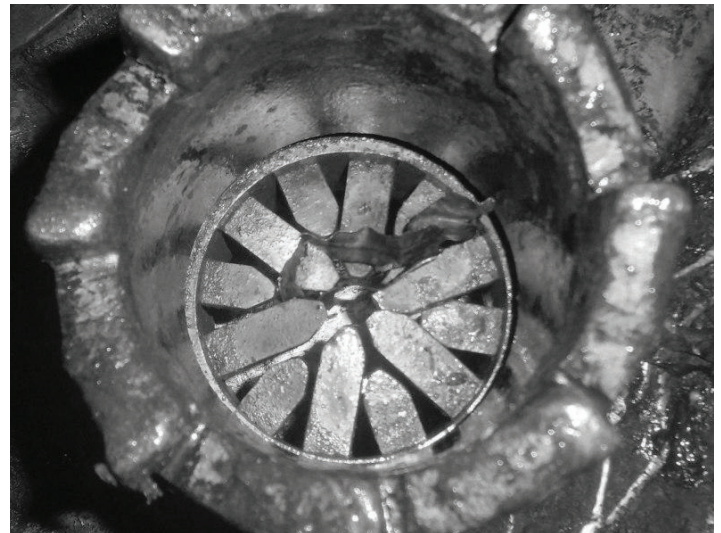

20.1.3] Density Tables

The following table gives a comparison of densities of typical banding materials that are used. Polymer based banding systems have the advantage of densities that are close to water and therefore can be flushed out more easily should the need arise.

Material	Density
	g/cm ³ (oz/inch) ³
PA66	1.14 (0.66)
PA12	1.01 (0.59)
PK	1.24 (0.72)
PPS	1.25 (0.72)
PEEK	1.30 (0.75)
Carbon Steel	7.85 (4.54)
Stainless Steel 304	8.03 (4.64)

21.1] Test Validation



Where applicable product testing is witnessed and validated by SGS.

SGS are a world leading inspection, verification, testing and certification company with a network of 2600 offices and laboratories worldwide.

www.sgs.co.uk

21.2] Quality Control



HCL Fasteners Limited is committed to the manufacture / supply of plastic and metallic clamping solutions and ancillary products across a wide variety of sectors and markets. Focus will be given to:

- 1) Meeting or exceeding the customers' specified requirements and reasonable expectations.
- 2) Working within the framework of statutory, regulatory and legal requirements.
- 3) Ensuring products sent to customers are correct and arrive in good time and in good condition.
- 4) Managing risks, process inputs and process outputs to ensure consistent products.
- 5) Continually improving, growing and developing the business using a Quality Management System that conforms to the requirements of ISO9001-2015 to ensure consistent quality in all work undertaken.
- 6) Establishing and communicating measureable Quality Objectives that will reflect the company strategy and will be subject to review to ensure ongoing relevance and performance.
- 7) Ensuring that Quality and Continual Improvement are responsibilities for all employees, in every activity, throughout the company.
- 8) Supporting all employees according to their individual needs for personal development, training and resources.



Injection Moulding & Extrusion Control

HCL's banding products are manufactured to the highest standard using the latest equipment and techniques. The injection-moulding and extrusion machines are computer controlled and the settings for each mould tool are recorded for maximum repeatability. Before a production run can begin, the first-off components must be checked and approved against their specification. The machines also have quality control capabilities where parameters, e.g. melt cushion, are given an acceptable tolerance range.

Statistical Process Control

SPC data relating to each manufacturing batch is entered into a computer for dimensional verification and weight checks. The SPC sample and a hard copy of the SPC data are stored for reference and product traceability.

First and Last off samples for each batch of banding products are tested using calibrated Zwick Tensile testing machines, to ensure that they meet the required performance.

Routine Production Checks

Products found to be outside specification are rejected, and the batch concerned isolated. Settings are adjusted until satisfactory yield is achieved and the suspect batch subject to 100% inspection.

Final Inspection

All products are given a final visual and physical inspection during packaging.

If required, a certificate of conformity to HCL's product specification can be issued.

Quality Policy

HCL is committed to the highest possible quality standards. Quality control systems are subject to review at appropriate intervals in consideration of the following:

- a) Changes in technology
- b) Changes to markets
- c) Changes in legislation
- d) External assessor's reports
- e) Overall company facilities & policies

Your attention is drawn to the following:

The statements, technical information and recommendations contained herein are believed to be accurate as of the date hereof. Since the conditions and methods of use of the product and of the information referred to herein are beyond our control, HCL expressly disclaims any and all liability as to any results obtained or arising from any use of the product or reliance on such information; NO WARRANTY OF FITNESS FOR ANY PARTICULAR PURPOSE, WARRANTY OR MERCHANTABILITY OR ANY OTHER WARRANTY, EXPRESS OR IMPLIED, IS MADE CONCERNING THE GOODS DESCRIBED OR THE INFORMATION PROVIDED HEREIN. The information provided herein relates only to the specific product designated and may not be applicable when such product is used in combination with other materials or in any process. The user should thoroughly test any application before commercialization. Nothing contained herein constitutes a license to practice under any patent and it should not be construed as an inducement to infringe any patent and the user is advised to take appropriate steps to be sure that any proposed use of the product will not result in patent infringement.

The information contained in this document is based on trials carried out in our internal laboratory and data selected from other literature, but shall in no event be held to constitute or imply any warranty, undertaking, express or implied commitment from our part. Our formal specifications define the limit of our commitment. No liability whatsoever can be accepted by HCL with regard to the handling, or use of the product or products concerned which must in all cases be employed in accordance with all relevant laws and/or regulations in force in the country or countries concerned.

HCL – UK & Rest of the World

Tel: +44 (0)1761 417714

Fax: +44 (0)1761 417710

Email: sales@hcl-clamping.co.uk

HCL – North America

Tel: 281-717-1145

Fax: 281-717-1146

Email: sales@hcl-clamping.com

Visit www.hclfasteners.com to view our complete range of products.

November 2020



COMPANY WITH
QUALITY SYSTEM
CERTIFIED BY DNV GL
= ISO 9001 =