

# DEFENDER™ FS

## Sealing/Isolating Gaskets and Flange Isolation Kits

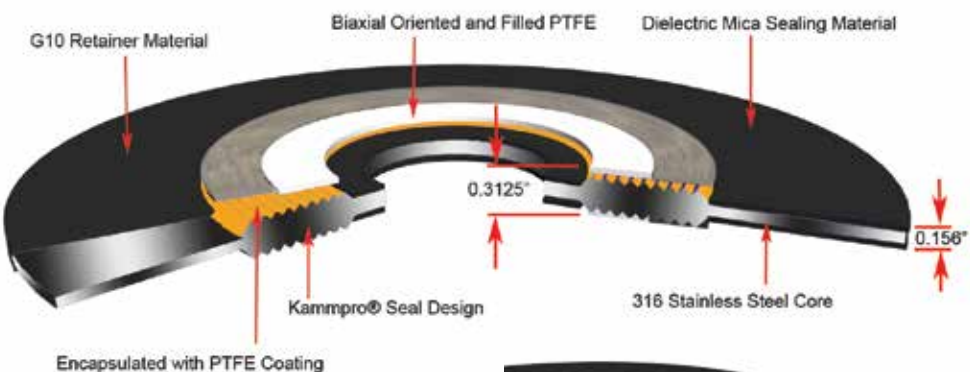

Sealing Global - Servicing Local



The DEFENDER FS™ sealing/isolating gasket is designed to withstand the rigorous API standard 6FB (Third Edition) test and therefore provides a solution for those who want to electrically isolate their flange while also requiring protection against the introduction of fire in and around the flange.

The objective of the test is to monitor the total leakage for the duration of the burn/cool-down cycle and during re-pressurization. Leakage was determined by the total water level drop through a visual sight gauge during the burn/cool-down cycles, by manually catching the water in a calibrated container during re-pressurization.

The results concluded that the Defender FS Gasket was able to maintain its fire safe characteristics throughout the entirety of the test. During the 30 minute burn and 30 minute cool down period, the measured leakage was 0 ml/min versus the allowable rate of 22.765 ml/min. The leakage rate during the re-pressurization cycle was 5 ml/min versus the allowable rate of 22.765 ml/min.

Based on years of technological experience, the DEFENDER FS™ sealing/isolating gasket not only meets but exceeds the pressure-containing capabilities in standard 6FB (Third Edition) as outlined by API.

### General Features

- Tested and Certified to API 6FB (Third Edition).
- Two integral robust sealing elements for sealing and isolating in an engineered Fire Safe design.
- Serves as a sealing/isolation for Fire Safe Applications.
- Incorporates industry proven Kammpro® sealing technology.
- Patent Pending Design.
- Inconel and Super Duplex Steel Cores available upon request.

### Applications

DEFENDER FS gaskets were engineered for Fire Safe, extreme, high reliability sealing and electrical isolation critical service applications

- High Pressure Flanges: 2500#, API 15K or PN420.
- Critical/Extreme service
- High Ph service.
- H<sub>2</sub>S/CO<sub>2</sub> service.
- Locations where end users prefer an integral seal element and when highly volatile fluids are present.

### Sizes

- 1/2" through 48" diameter.
- Available as "E" or "F" Type Gaskets.



Protect your investment with Fire Safe products at critical applications where Fire is at high risk. The DEFENDER FS is a Fire Safe product that allows a work force at production facilities and Offshore platforms extra time to prevent devastation and harm. Seconds count when valves and flanged applications need to be shut down in emergency situations.

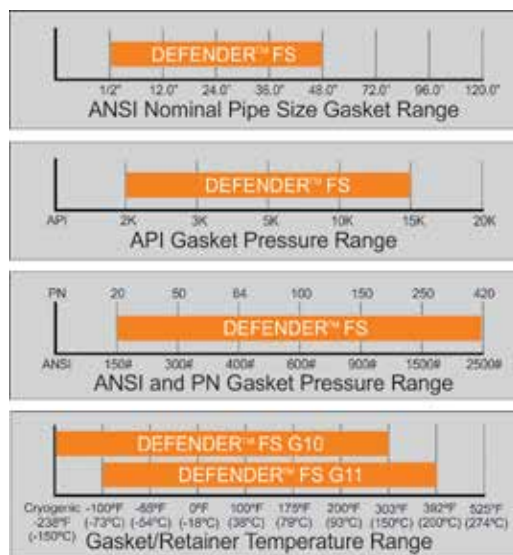

For applications outside ranges shown, consult factory.



### Before Tightening

The flange face makes initial contact with the sealing elements which protrude above the gasket retainer surface (isolation material) laminated on both sides of the stainless steel core.

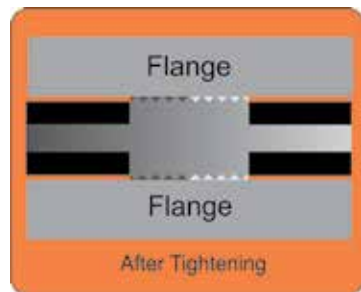

### After Tightening

The sealing elements are compressed into the serrations of the stainless steel retainer.

### Type "E" Gasket

Fits over the bolt holes and extends to the O.D. of the flange to assist contractors as the bolt holes automatically center the gasket. Provides excellent protection against shorting out of the corrosion mitigation hardware.



### Type "F" Gasket

Fits within the bolt hole circle of the flange and extends to the I.D. of the bolt circle providing good protection against shorting out of the corrosion mitigation hardware.

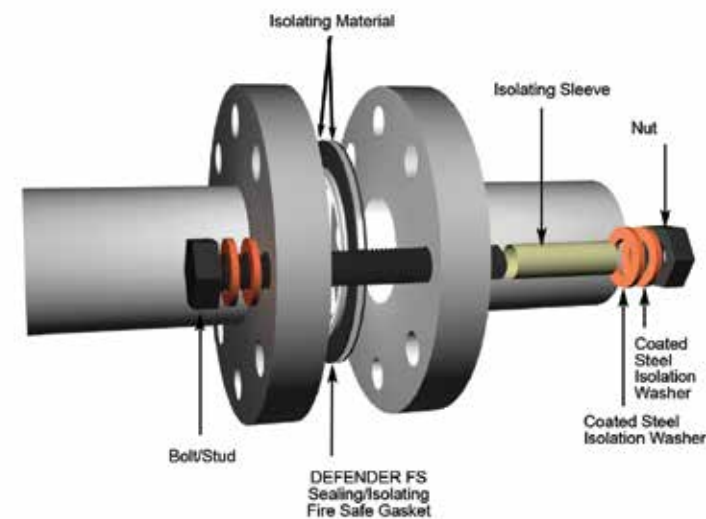

### Gasket/Retainer Material Specifications Retainer Material (G10S6, G11S6)

- 0.3125" (7.94mm) total thickness
- Metal Core .1/4" (.250"- 6.35mm) thick - 316SS
- Laminate .032" (0.812mm) per side

Note: Consider G10S Material for applications of Nominal Pipe Size 12-inch and larger and ANSI pressure class 600# and higher.

ASTM	TEST METHOD	G10	G11
D149	Dielectric Strength Volts/Mil Short Time	750-800	550
D695	Compressive Strength (psi)	65,000	63,000
D570	Water Absorption (%)	0.05	0.10
D790	Flexural Strength (psi)	65,000	60,000
D256	IZOD Impact Strength (Ft-Lbs/Inch)	14.00	12.00
D638	Tensile Strength (psi)	50,000	42,000
D732	Shear Strength (psi)	21,000	21,000
D952	Bond Strength (lb)	2,600	2,200
	Temperature - Operating	Cryogenic -100°F (-238°F (-150°C) to +302°F (+150°C)	-100°F (-73°C) to +392°F (+200°C)

NOTE: Operating Temperature for Gaskets and Flange Isolation Kits is based off the Gasket Retainer Temperature. Seal element temperature does not dictate the Min. and max. gasket operating temperature. Performance suitability and material compatibility shall be determined by the user. The DEFENDER FS is an engineered fire safe gasket that has passed API 6FB fire test (Third Edition). No other claims regarding suitability/compatibility for a particular application or performance in a fire are made.

### Seal Element Materials

Sealing Element	Temperature - Operating
Mica (Hi-Temp)	+1,832°F. (+1,000°C.)
Biaxial Oriented PTFE	-450°F (-268°C) to +500°F (+260°C)
Kammprofile PTFE Coating	-58°F (-50°C) to +350°F to (+176°C)



### Industries (Oil, Gas, Offshore)

Production Fields, Petroleum Marketing Facilities, LNG/SNG Systems, Pipeline and Distribution Piping, Refineries, Tank Farms, Offshore platforms.

### DEFENDER FS Flange Isolation Kits

For a flange isolation kit, sleeves and washers are needed. Generally, 95% of steel core flange isolation kits are sold with G10 and G11 sleeves and Mica Isolation Washers.

### Suggested Sleeve and Washer Set



FD = G10 and G11 Sleeves, Mica Washers and metallic Washers - Double Washer Set

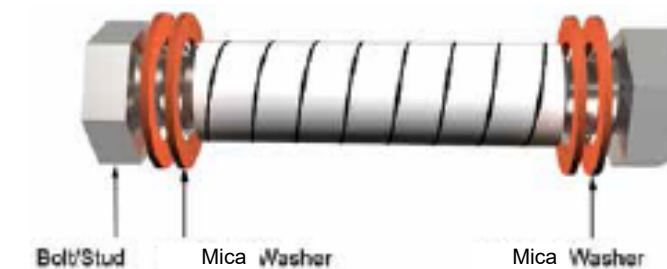

TFD = Nomex Sleeves, Mica Washers and metallic Washers - Double metallic Washer Set

# DEFENDER™ FS Sealing/Isolating Gaskets and Flange Isolation Kits



Lamons of Houston, TX requested that United Valve Inc. of Houston, Texas test and evaluate the Lamons 6" #300 Class Defender FS Gasket's pressure containing capabilities the API standard 6FB(Third Edition, Nov. 1998, Non bending, On shore or Open Offshore Fire Test). The test involved of affixing the gasket between two flanges and fitting the flanges to United's test setup. The gasket was then subject to burn cycle at an average flame temperature between 1400°F and 1800°F for 30 minutes while maintaining 555 psi. Upon completion of the burn, the pressure was then held during a 30 minute cool down to a temperature below 212°F. The gasket was depressurized and then pressurized back to 555psi and held for an additional 5 min.

The objective of the test was to monitor the total leakage during the duration of the burn/cool down cycle, along with the repressurization cycle with accordance to API 6FB standards.

Leakage was determined by the total water level drop through a visual sight gauge during the burn/cool down cycles, and then by manually catching the water in a calibrated container during the repressurization cycle.

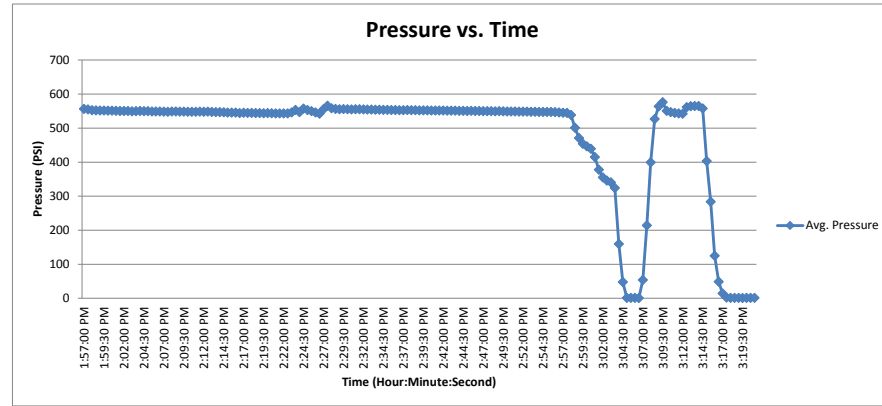

## Test Procedure:

Below is a summary of the test setup and protocol performed during the gasket fire test with accordance to API 6FB, Third Edition Non Bending, On shore or Open Offshore Fire Test.

1. Install the Defender FS gasket between two CS flanges.
2. Bolt the flanges together using the supplied B7 Studs, 2H Nuts, Dielectric Sleeves, and Coated Steel Washers
3. Apply non conductive PTFE lubricant to studs/bolts and torque to 225 ft. lbs.
4. Thread NPT pipe fittings into flanges and affix the flange package in the test setup.
5. Connect all pressure and temperature monitoring equipment in their correct positions. This consists of 2 flame thermocouples, 3 thermocouples and 3 calorimeter cubes spaced 120° apart around the circumference of the flange (respectively), and a 4th calorimeter/thermocouple cube placed furthest away from the flame sources.
6. Hydrotest the assembly to 555 psi to check all fittings/connections for leaks prior to testing.
7. Confirm pressure and ignite the burners under the flange assembly and start the burn cycle clock.
8. Per the test protocol, the average temperature of the flame thermocouples must reach 1400°F within 2 minutes of ignition, and maintain an average temperature between 1400°F and 1800°F with no reading less than 1300°F until the average calorimeter temperature reaches 1200°F.
9. The average temperature between the 4 calorimeter cubes must reach 1200°F within 15 minutes of the burner ignition.
10. Conduct the burn cycle for at least 30 minutes.

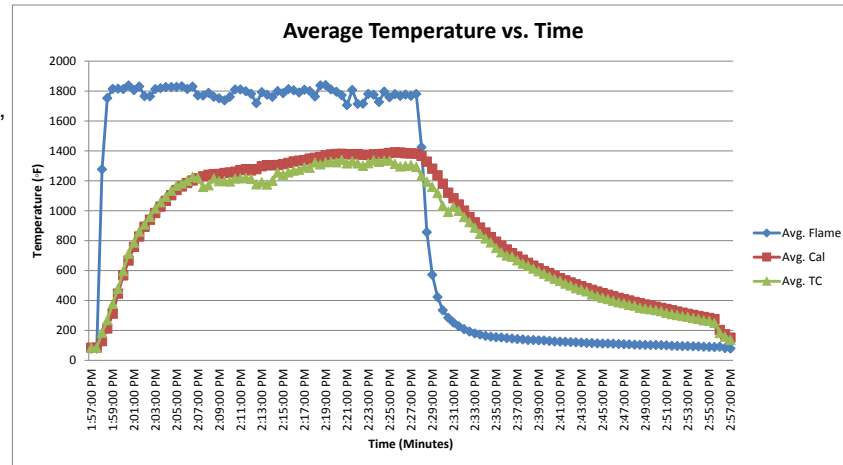

11. Upon completion of the burn cycle, cool the valve below 212°F.
12. Depressurize the system.
13. Re-pressurize the system to 555 psi and hold for 5 minutes.
14. Determine the allowable leakage rates:  
 $AL = SD \times 3.41 = 7.25 \times 3.41 = 22.765 \text{ in.}$   
 Where: AL= Allowable Leakage  
 SD= Mean Gasket Seal Diameter
15. Compare the actual leakage rates vs. the allowable rate.



VARIABLE	DATA RECORDED
Average System Pressure	550.59 psi
Average Flame Temperature	1722.72°F.
Time to reach flame temperature of 1400°F.	1 minute, 30 seconds
Average Calorimeter Temperature	1329.4°F.
Time to reach average calorimeter temp. of 1200°F.	10 minutes, 30 seconds
Total Burn Time	30 minutes
Total Cool Down Time	30 minutes
Total Repressurization Hold Time	5 minutes
Average System Pressure during Repressurization	556.71 psi



DEFENDER™ FS Sealing/Isolation Gaskets are suggested for RTJ Applications vs. Phenolic Ring Type Gaskets.

